

# Operating Instructions

## ProMinent® Sigma/ 1

### S1Ba (Basic Type)

### S1Ca (Control Type)

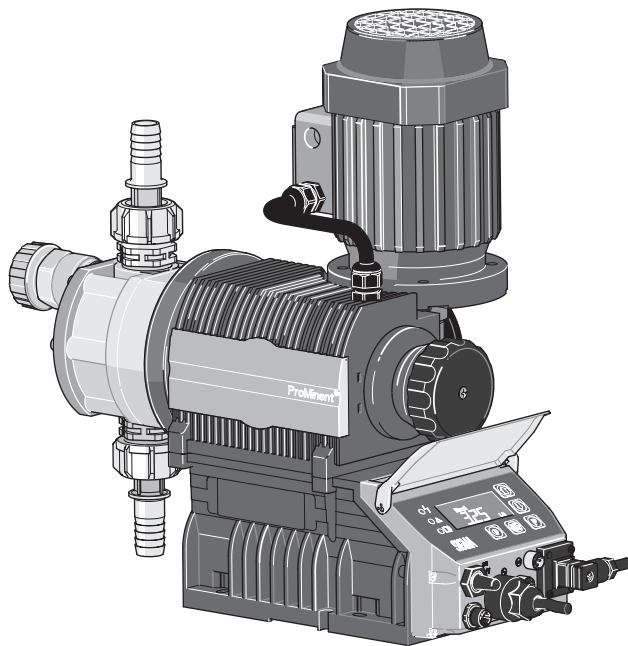

S1Ca

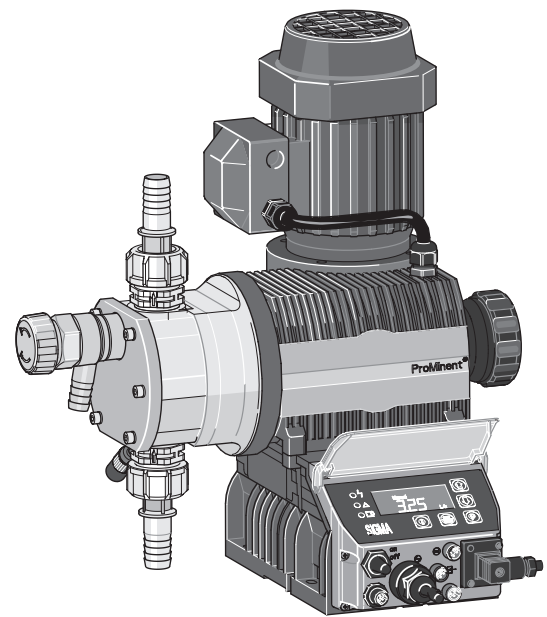

S1Ca  
with left-hand liquid end

Two sets of operating instructions are necessary to ensure the ProMinent® Sigma/ 1 S1Ba or S1Ca metering pumps are operated safely and reliably for their intended purpose:

This product specific Sigma/ 1 operating instructions manual and the "General operating instructions ProMinent® motor-driven metering pumps and hydraulic accessories" are only valid if read together!

**Please completely read through these operating instructions first! · Do not discard!**

**The warranty shall be invalidated by damage caused by operating errors!**

## Control elements and key functions

### Control elements: overview

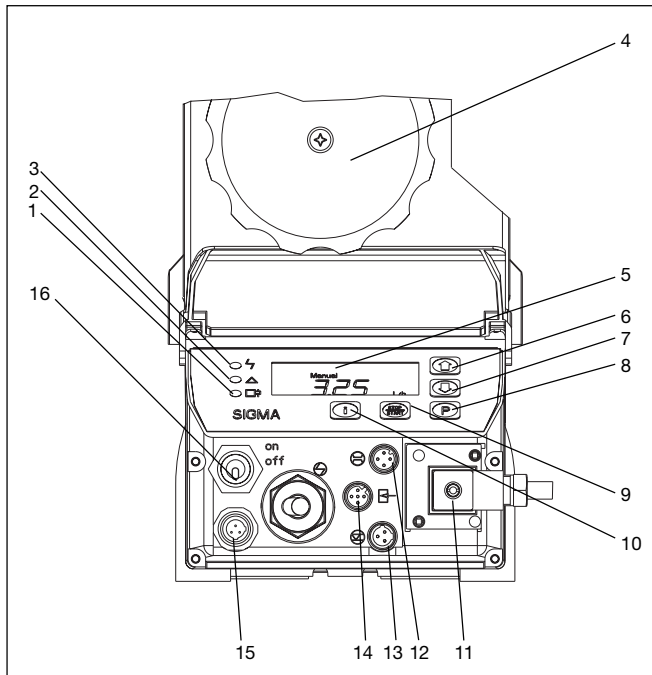

- 1 Operating light (green)
- 2 Warning light (yellow)
- 3 Error warning light (red)
- 4 Stroke length adjuster
- 5 LCD display
- 6 UP key
- 7 DOWN key
- 8 P key
- 9 STOP/START key
- 10 i key
- 11 Relay output (optional)
- 12 Metering monitor socket
- 13 External control socket
- 14 Float switch socket
- 15 Diaphragm rupture indicator socket
- 16 Mains switch

### Key functions

#### In continuous display mode (operating)

#### In settings mode (settings)

#### STOP/START key



Press briefly

Stop pump,  
start pump

Stop pump,  
start pump

#### P key



Press briefly

Start batch (in "batch" operating mode only),  
Cancel error

Confirm entry- jump to next menu  
option or continuous display

Press for 2 s

Change to settings mode

---

Press for 3 s

---

Jump to continuous display

Press for 10 s

Software version displayed

---

Press for 15 s

Load factory settings (calibration)

#### i key



Press x1

Toggle between continuous displays

Toggle between "change individual digits"  
and change a figure"

Press x2

---

For "change individual digits":  
jumps to first digit

#### Arrow keys UP and DOWN



Press separately  
(until "Set" appears)

Change directly alterable values

Select other settings,  
change individual digit or figure

Press simultaneously

Prime (in "Stroke rate" permanent display)-

---

# Operating-/Settings Diagram

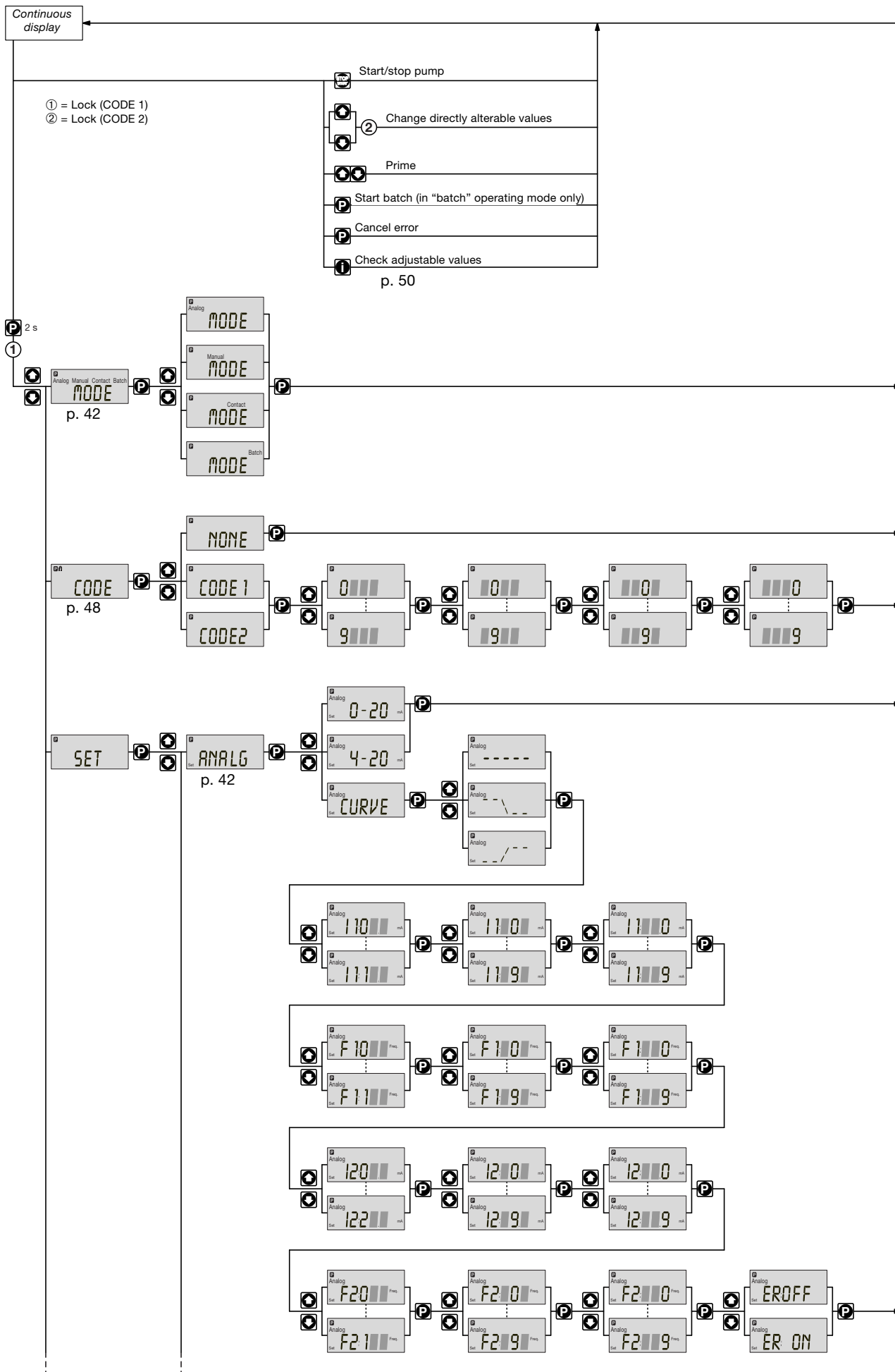

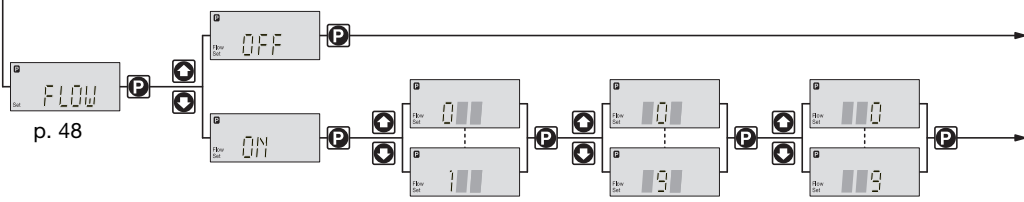
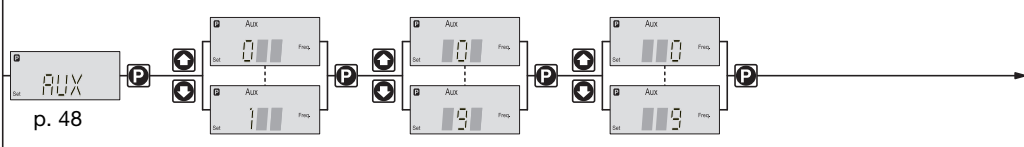
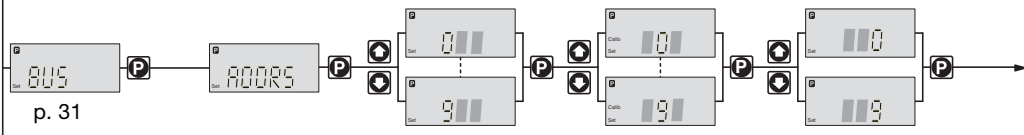
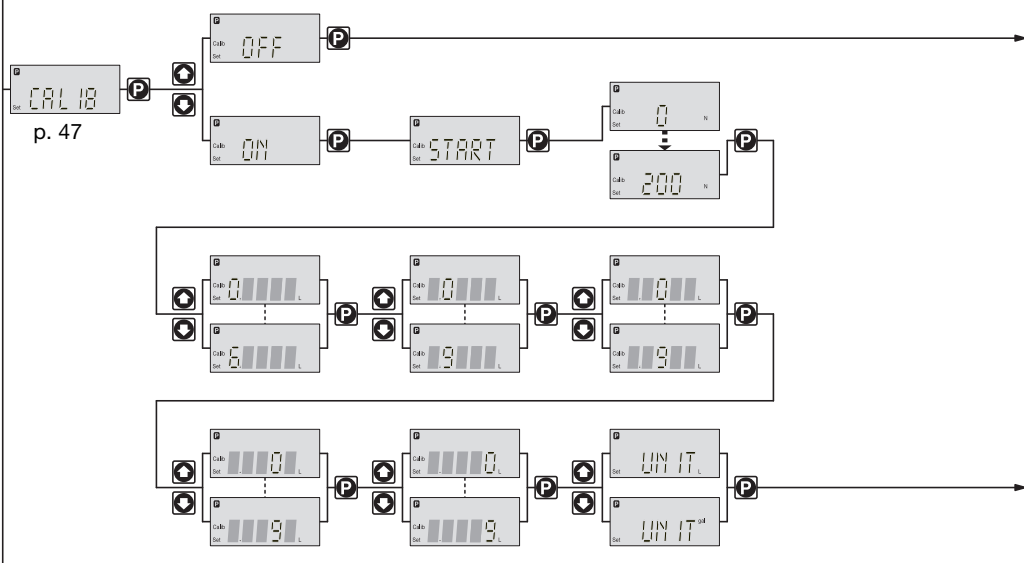
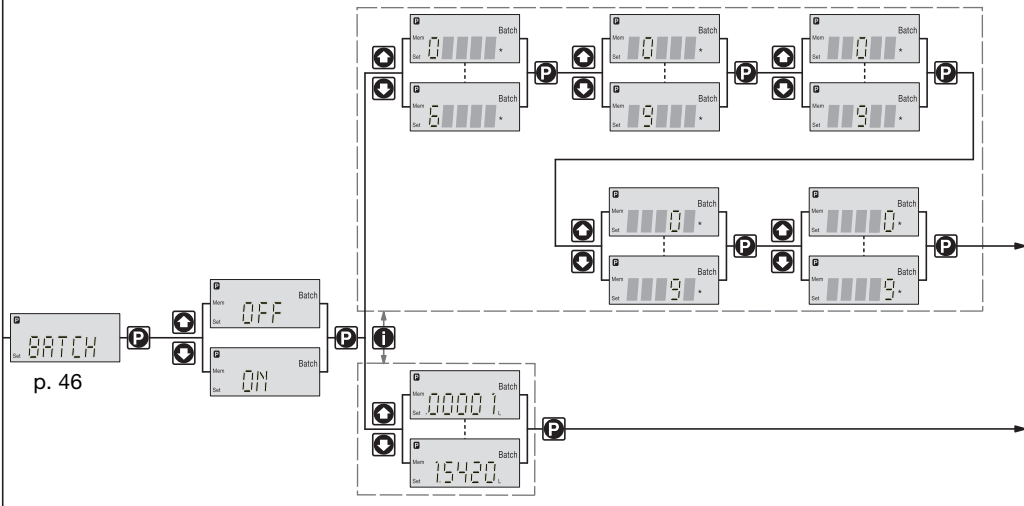
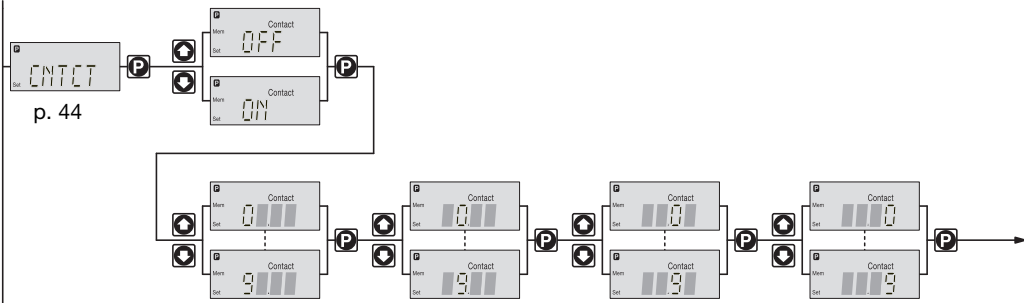

## Continuous display

Continuous display	Operating mode "Analog" 0-20 mA	Operating mode "Manual"	Operating mode "Contact" with memory and transfer factor 5	Operating mode "Batch" with memory and transfer factor 5
Stroke rate				
Feed rate				
Total stroke number				
Total litres (feed quantity)				
"External" display				
Signal current				
Strokes remaining				
Batch size/ Litres remaining				
Factor				
Stroke length				

⬆️⬆️ = UP and/or DOWN arrow keys, directly alterable values

"Mem" appears only when "memory" function activated

**Imprint**

Operating Instructions for ProMinent® Sigma/ 1 S1Ba/S1Ca  
© ProMinent Dosiertechnik GmbH, 2002

ProMinent Dosiertechnik GmbH  
Im Schuhmachergewann 5-11  
69123 Heidelberg  
P.O. Box 101760  
69007 Heidelberg · Germany  
info@prominent.de  
www.prominent.de

Subject to technical modifications.

	Page
Device Identification/Identity Code	9
<b>1 Notes on safety of ProMinent® metering pumps</b>	<b>11</b>
1.1 General notes	11
1.2 Notes on installation, start-up and operation	11
1.3 Notes on maintenance and repair	12
<b>2 Product description S1Ba/S1Ca</b>	<b>13</b>
2.1 Identification of pump type	13
2.2 Design/Functional description	13
2.2.1 Functional description, drive	13
2.2.2 Stroke movement	14
2.2.3 Metering capacity diagram	15
2.2.4 Functional description, delivery unit	17
2.2.5 Integrated overflow valve with bleeder function	18
2.2.6 Diaphragm rupture sensor	20
<b>3 Technical data</b>	<b>23</b>
3.1 Technical data Sigma/ 1	23
3.1.1 Capacity data	23
3.1.2 Dimensions Sigma/ 1	25
3.1.3 Dimensions Sigma/ 1 with servo motor	26
3.1.4 Dimensions Sigma/ 1 with left hand liquid end	27
3.1.5 Motor data	27
3.1.6 Stroke adjuster	28
3.1.7 Stroke actuator	28
3.1.8 Electrical data, stroke sensor “S1Ba”	28
3.1.9 Electrical data, pacing relay “S1Ba”	28
3.1.10 Sound intensity level	28
<b>4 Start-up/Maintenance</b>	<b>29</b>
4.1 Start-up	29
4.2 Maintenance	29
4.3 Replacement of wearing parts	29
<b>5 Features of the S1Ca metering pumps</b>	<b>31</b>
5.1 Function description, motors	31
5.2 Function description, controller	32
5.3 Sockets, symbols and wiring diagram	34
5.4 Retrofitting relays	39

<b>6</b>	<b>Control elements</b>	<b>40</b>
<b>7</b>	<b>Settings</b>	<b>41</b>
7.1.	Check adjustable values	42
7.2	Change to settings mode	42
7.3	Select operating mode (MODE menu)	43
7.4	Settings for operating mode (SET menu)	43
7.4.1	Settings for “manual” operating mode	43
7.4.2	Settings for “analogue” operating mode (ANALG menu)	43
7.4.3	Settings for “contact” operating mode (CONTCT menu)	45
7.4.4	Settings for “batch” operating mode (BATCH menu)	47
7.5	Settings for programmable functions (SET menu)	47
7.5.1	Settings for “calibration” function (CALIB menu)	47
7.5.2	Setting for “auxiliary frequency” function (AUX menu)	48
7.5.3	Settings for the “flow” function (FLOW menu)	49
7.6	Setting code (CODE menu)	49
7.7	Cancel total stroke number or total litres (CLEAR window)	49
<b>8</b>	<b>Operating</b>	<b>50</b>
8.1	Manual operation	50
8.2	Remote control	51
<b>9</b>	<b>Troubleshooting</b>	<b>51</b>
<b>10</b>	<b>Decommissioning and disposal</b>	<b>53</b>
<b>11</b>	<b>Spare parts and accessories</b>	<b>54</b>
	<b>Annex</b>	<b>55</b>
	Motor data sheet	55
	EC Declaration of Conformity	56
	Exploded diagrams of liquid ends	57
	Stroke actuator wiring diagram	63
	Stroke adjuster wiring diagram	63





## 1 Notes on safety of ProMinent® metering pumps

Notes on safety and important operating notes are divided into classes accompanied with pictograms. Please familiarize yourself with the following definitions and pictograms.



### **DANGER**

Danger to life or risk of serious injury!



### **WARNING**

Danger of injury or serious damage to the device!



### **NOTICE**

These situations require complete attention!

### **IMPORTANT**

Information which must be followed!

### 1.1 General notes



#### **WARNING**

- The equipment/devices may only be used for their intended purpose.
- ProMinent® metering pumps must not be assembled with parts which are not tested and recommended by ProMinent otherwise this can lead to injury to persons and damage to property for which no liability will be accepted!
- Pumps must be accessible at all times to facilitate operation and maintenance. Access points must not be obstructed or blocked!
- Before carrying out any maintenance and repair work always drain off and flush out the liquid end first if hazardous or unknown metered media are used!
- When metering hazardous or unknown liquids, always wear safety clothing (safety goggles, gloves, ...) when working on the liquid end!
- You must observe the guidelines in this operating instructions manual and the "General operating instructions manual for ProMinent® motor-driven metering pumps and hydraulic accessories" on assembly, installation and maintenance!

### 1.2 Notes on installation, start-up and operation



#### **WARNING**

- The metering pump can contain water residue in the liquid end as the result of testing at the factory!

If handling media which must not come in contact with water, all traces of water must be removed from the liquid end before start-up! For this purpose, turn the pump through 180° and drain off the liquid end then flush with a suitable medium from above via the intake connection!

- Do not connect mains voltage to the control cable!
- When operating the metering pump against a closed shut-off element on the pressure side or in the event of pressure peaks during the metering stroke, the system pressure can reach a multiple of the maximum permissible operating pressure that can consequently cause the pressure line to burst!
- To avoid this situation, an overflow is recommended for the purpose of limiting the maximum permissible operating pressure of the pump or system.
- Do not connect a metal bypass line to the overflow valve on the PVT delivery unit! This could cause cracks in the delivery unit!
- The bearing cover (1) must be fitted when in operation. The equipment will not otherwise comply with IP 55 and the bearing will not be adequately secured!
- The design cover (2) must be fitted when in operation. Equipment will not otherwise comply with IP 55.

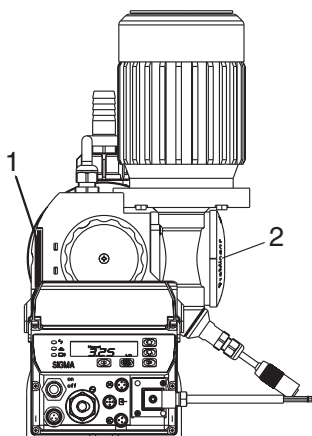

Fig. 1



**NOTICE**

- **Set stroke length only with pump in operation!**

**IMPORTANT**

- The pump must be secured in such a way that no vibrations can occur! The valves of the liquid end must always be positioned vertically in order to ensure trouble-free operation!

- The intake and delivery lines must always be arranged such as to ensure connection at the liquid end free of mechanical stress!

The lines must be secured such that no vibrations can occur!

- Only use the clamping rings and hose sockets intended for the relevant hose diameter as well as original hoses with the specified hose dimensions and wall thickness otherwise the stability and durability of the connection will not be guaranteed!

Avoid reducing hose sizes!

Observe the permissible pressure of the hoses!

- A vent with return to the supply tank is advisable when metering extremely aggressive or hazardous media!

In addition, a shut-off valve should be provided on the delivery or intake side!

### 1.3 Notes on maintenance and repair

**WARNING**



- **Only specially trained and authorized persons are permitted to carry out maintenance on metering pumps and their periphery!**
- **If hazardous or unknown metering media are used, always flush out the liquid end first before carrying out any maintenance and repair work!**
- **When metering hazardous or unknown liquids, always wear safety clothing (safety goggles, gloves) when working on the liquid end!**
- **Always depressurize the delivery line first before carrying out any work on the pump!**  
**Always discharge and flush liquid end!**  
**Observe safety data sheets for metered liquid!**

**DANGER**



- **Disconnect power plug or power supply line before opening the plug!**  
**Isolate relay option if applicable!**  
**Check to ensure power is disconnected!**  
**Secure pump while carrying out repairs to ensure it cannot be switched on unintentionally!**
- **Pumps for metering radioactive media must not be shipped through standard channels!**

**IMPORTANT**

The metering pump must be in a cleaned condition with the liquid end flushed if returned for repair!

## 2

## Product description S1Ba/S1Ca

**WARNING****Use for intended purpose**

- The pump is designed as a liquid medium metering pump; it serves the purpose of metering liquid medium within the specified line system!
- Operate the pump only within the conditions described in the technical data!
- General restrictions with regard to viscosity limits, chemical resistance and density must be observed (refer to ProMinent® chemical resistance list (catalogue or homepage))!
- All other applications or conversion are prohibited!
- The pump is not designed to meter gaseous media as well as solids.
- The pump is not suitable for metering combustible liquids!
- Only specifically trained and authorized personnel are permitted to operate the pump!

## 2.1

## Identification of pump type

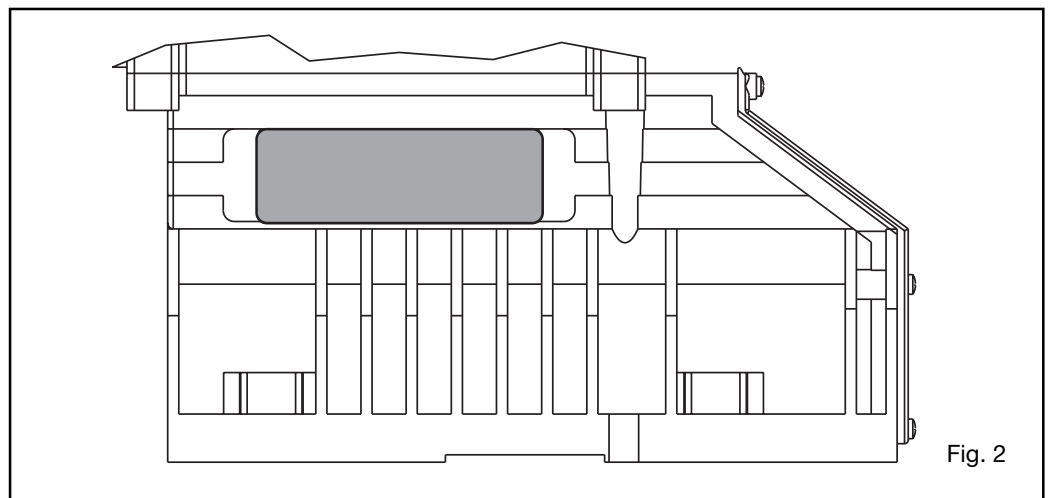

The identity code and serial number are given in addition to the standard technical specifications. These two numbers must always be quoted when making any enquiries as they enable distinct identification of the type of metering pump.

## 2.2

## Design/Functional description

## 2.2.1

## Functional description, drive

The ProMinent® Sigma/ 1 diaphragm-type metering pump is an oscillatory displacement pump with the stroke length adjustable in steps of 1%. It is driven by electric motor **(1)**. The rotary drive of the electric motor is stepped down by worm gear and transmitted via the eccentric roller **(3)** to the push rod **(4)** connected to fork **(8)** and converted into oscillatory movement. Return spring **(5)** presses the fork with push rod positively against the eccentric roller thus producing the return stroke. The stroke is adjusted by means of stroke adjustment knob **(6)** and spindle **(7)** by limiting the return stroke. Stroke movement is transmitted directly to the displacement diaphragm. Interacting with the valves, this diaphragm produces the overpressure and vacuum in the liquid end necessary for delivery. Flow is pulsating.

In the basic type, the electric motor is normally a 3-ph extended-range AC motor (refer to Section 3 for other options).

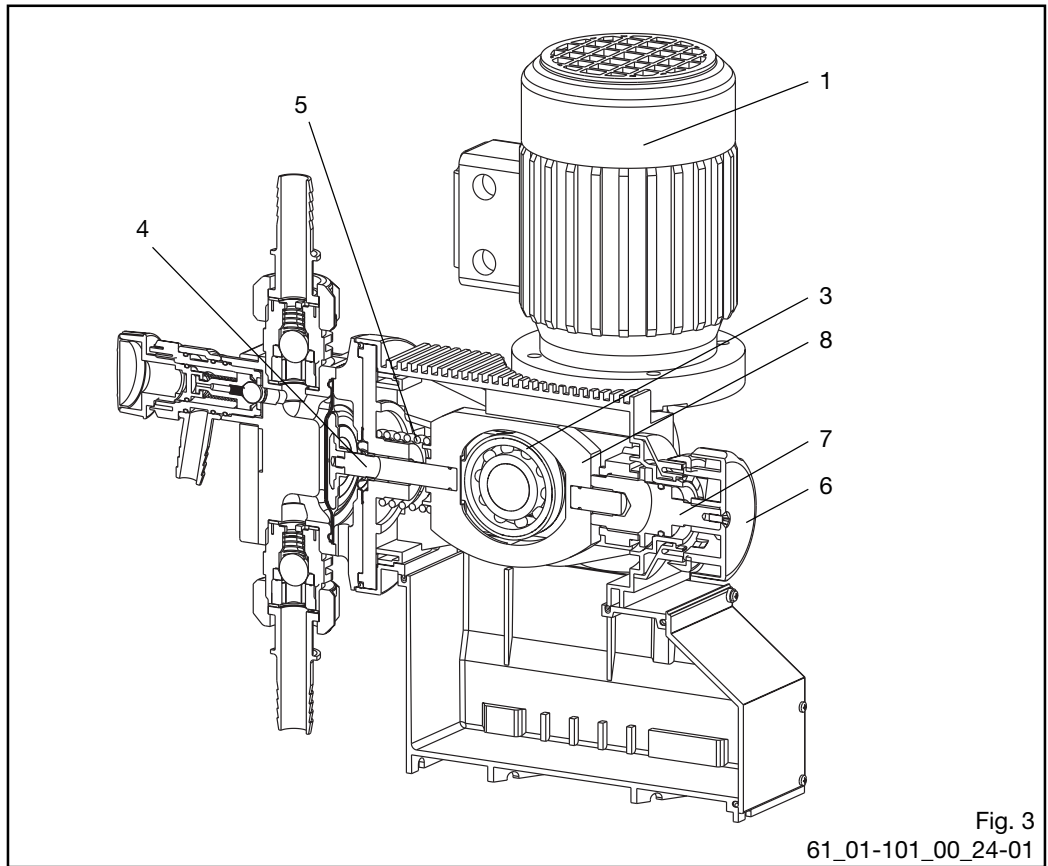

### 2.2.2 Stroke movement

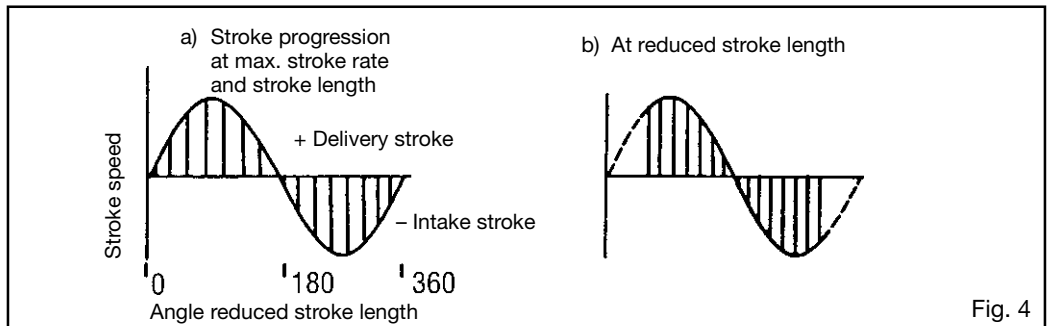

Set stroke length dependent on the required delivery capacity.

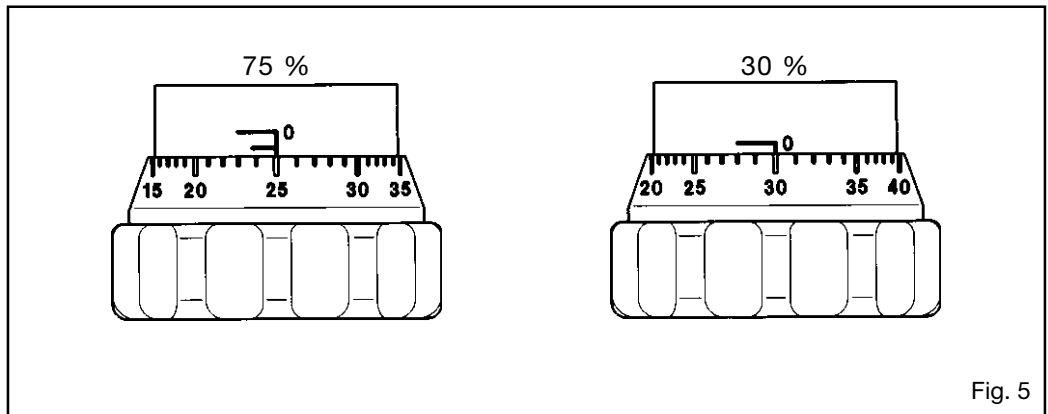

**IMPORTANT**

A large stroke length and low metering frequency should be selected for very viscous media!  
A shorter stroke length and high frequency should be selected to achieve good mixing properties!

### 2.2.3 Metering capacity diagram

Metering capacity diagram S1Ba (50 Hz)

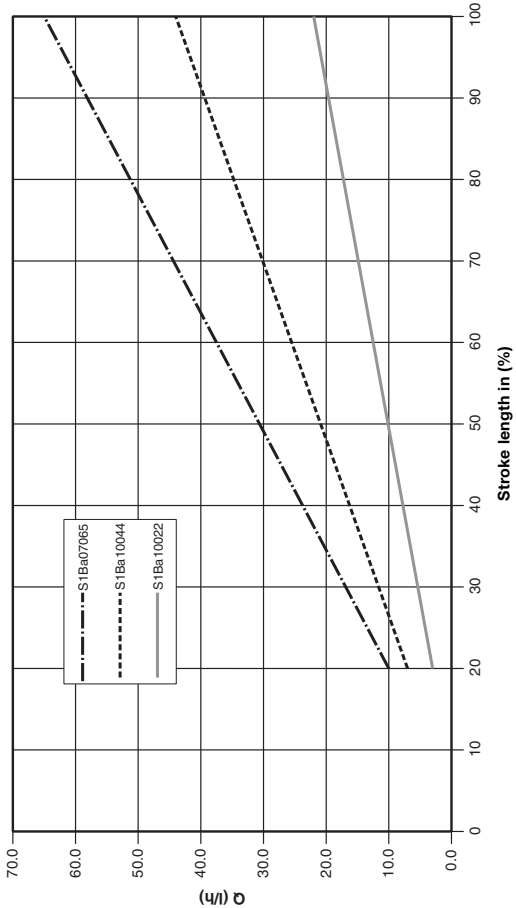

Metering capacity diagram S1Ba (50 Hz)

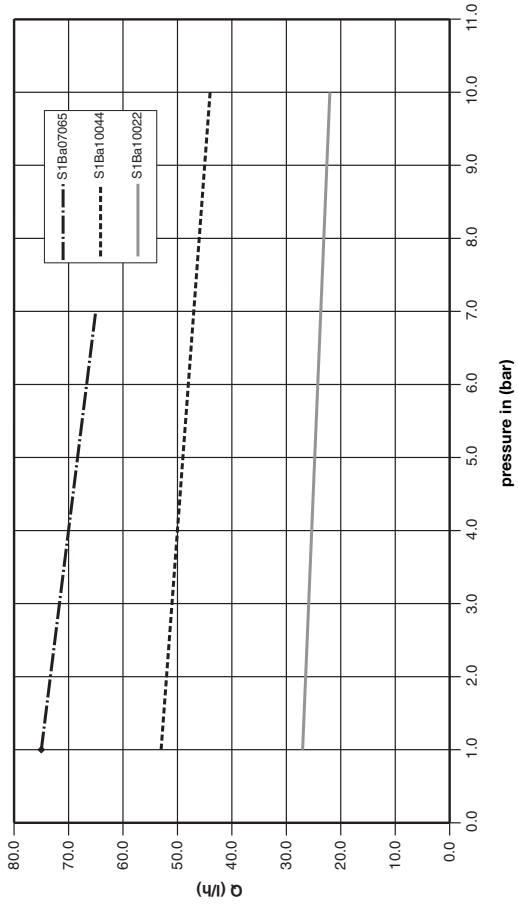

Metering capacity diagram S1Ba (50 Hz)

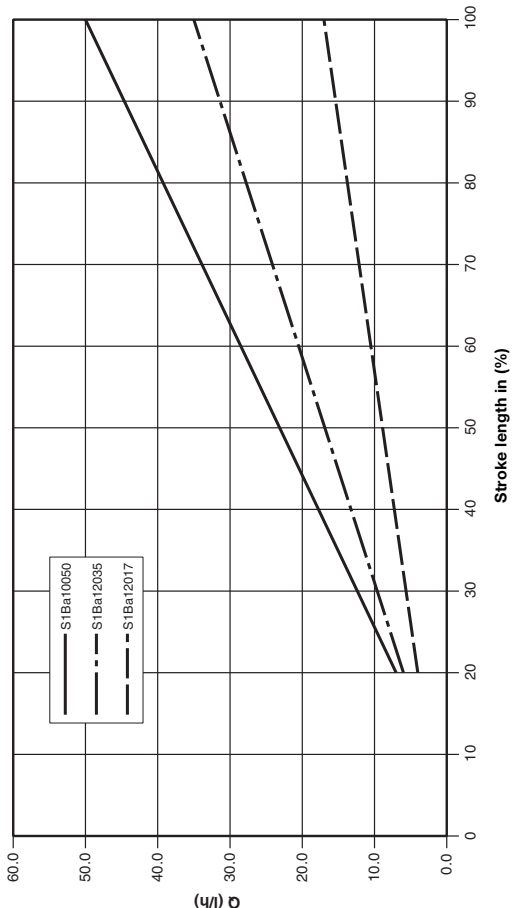

Metering capacity diagram S1Ba (50 Hz)

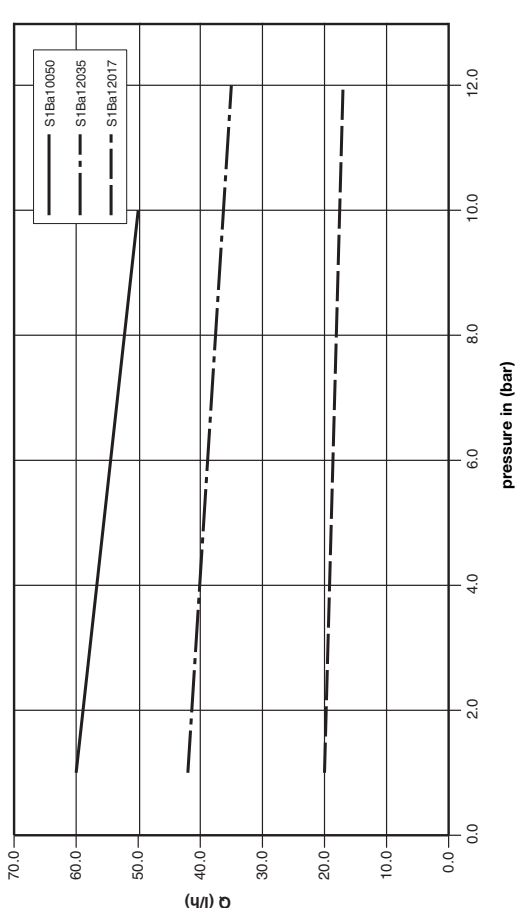

Metering capacity diagram S1Ba (50 Hz)

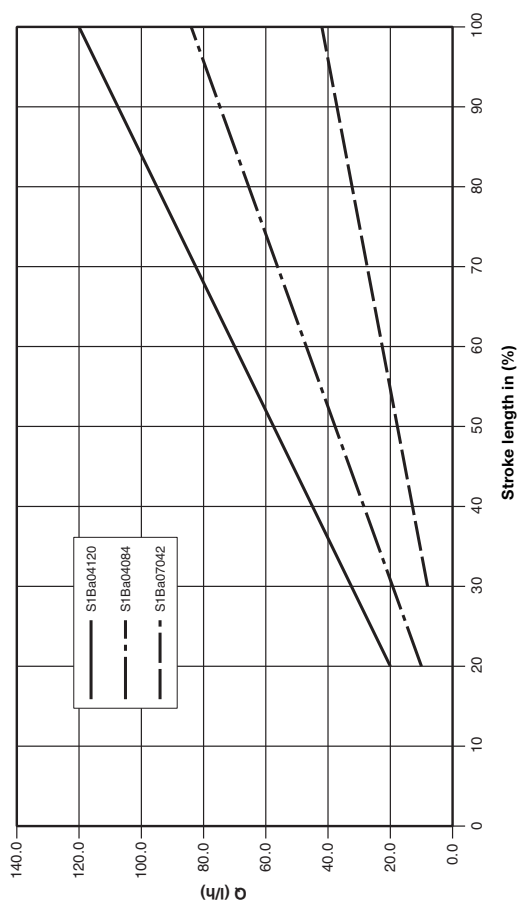

Metering capacity diagram S1Ba (60 Hz)

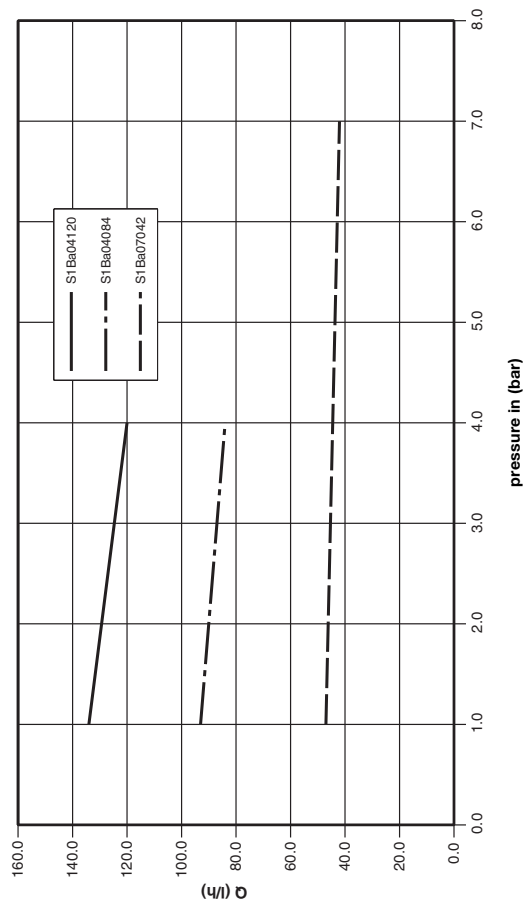

**IMPORTANT**

- The metering output of S1Ba at 60 Hz is approximately 1.2 times the metering output of S1Ba at 50 Hz.
- For pump types S1Ca, the output data at 60 Hz apply (for S1Ca, however, only 200 strokes/min. are possible).

### 2.2.4 Functional description, delivery unit

The heart of the delivery unit is the DEVELOPAN® metering diaphragm (2). It hermetically seals the delivery chamber of liquid end (4) and produces a displacement in the liquid end. The end disc (5) made of chemically resistant plastic together with safety diaphragm (13) separates the drive housing from the delivery unit and protects the drive from corrosion in the event of the diaphragm failing. Delivery is based on the interaction between intake valve (1) and head valve (3) of the same design together with the diaphragm movement. The valve balls can be supported with springs for metering viscous media.

The connection dimensions of valves and liquid ends of the same size but with different materials are identical. These parts can be interchanged as required.

Materials and dimensions are specified in Section 3, Technical data.

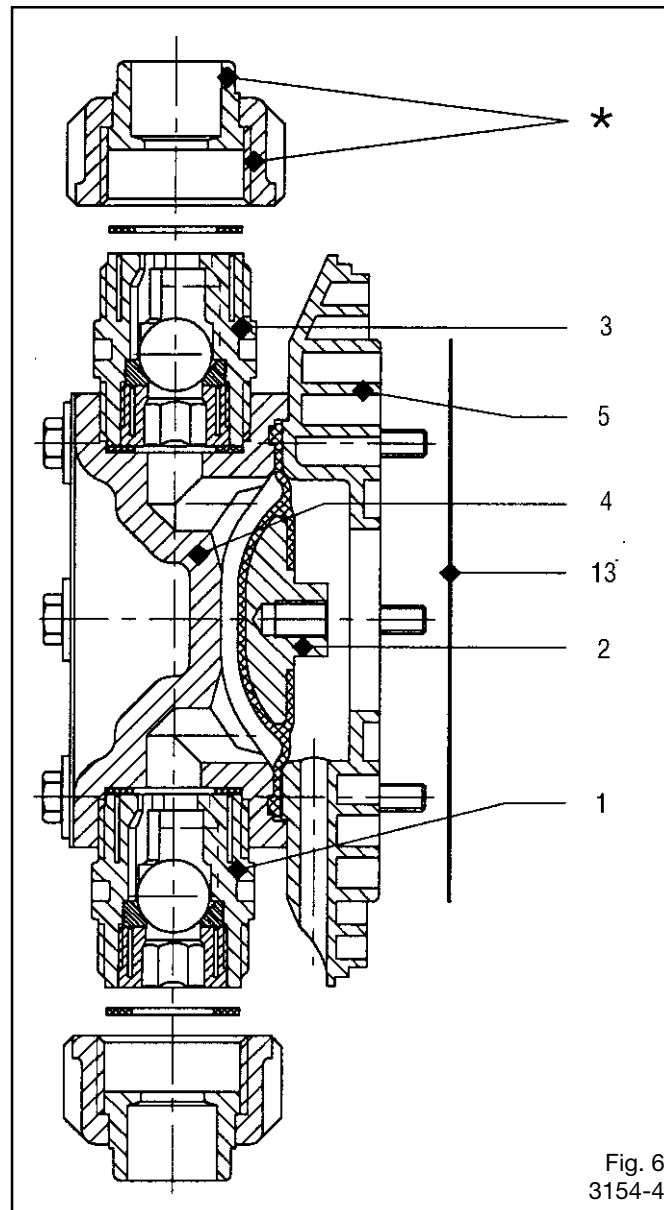

Fig. 6  
3154-4

## 2.2.5 Integrated overflow valve with bleeder function

### Task:

The task of the overflow valve is to protect the motor and gear unit against impermissible overpressure caused by the metering pump.

This function is produced by a spring-loaded ball.

A pressure relief mechanism for the bleeder function is provided.

### Design and functional description

(refer to Fig. No. 7 and 8)

Initially, the overflow valve illustrated under item 102 operates as a simple directly control **safety valve**. As soon as the pressure set with spring item 132 is exceeded, the effective pressure raises ball item 130. The liquid then flows off into the tank via hose connection item 128.

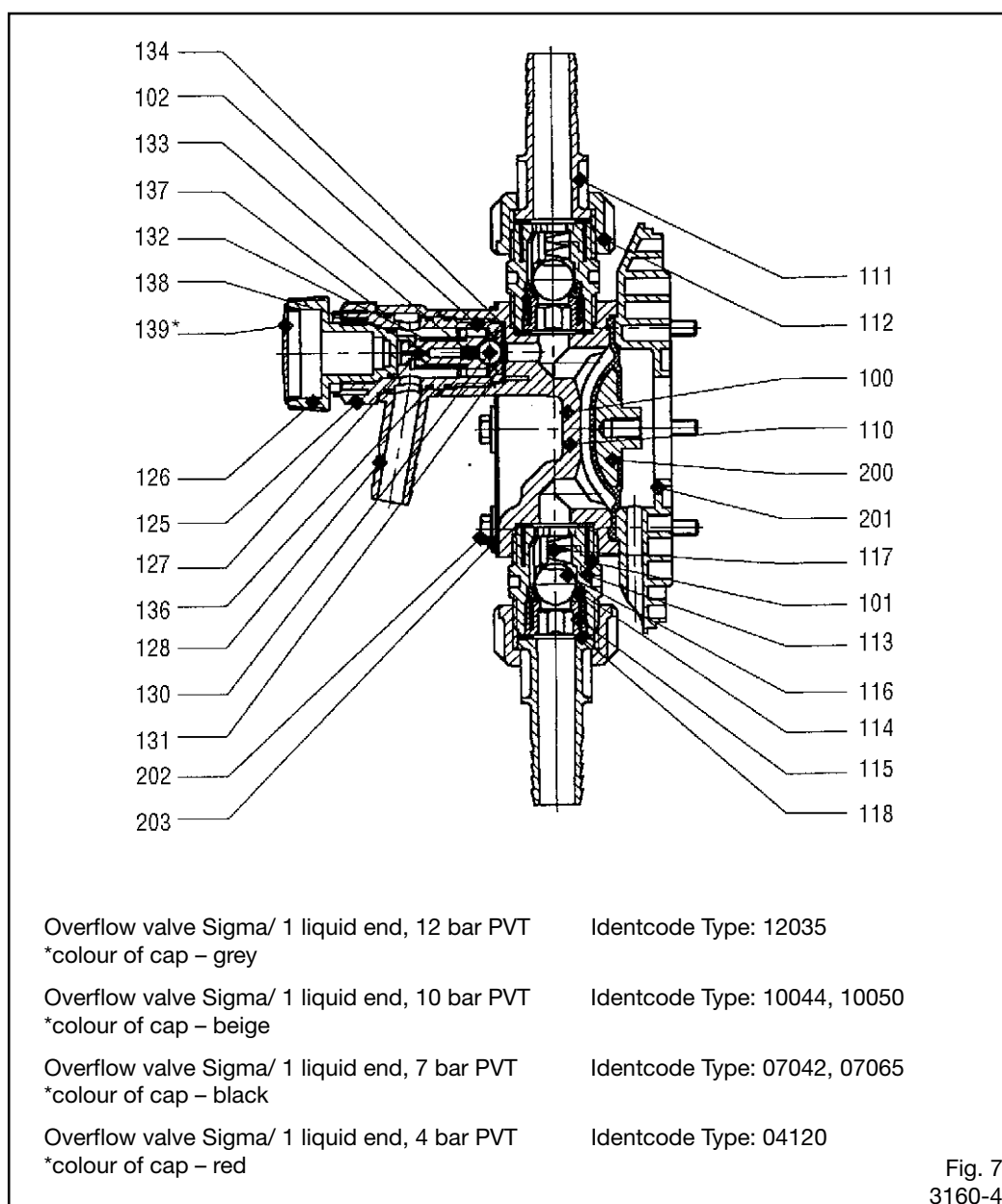

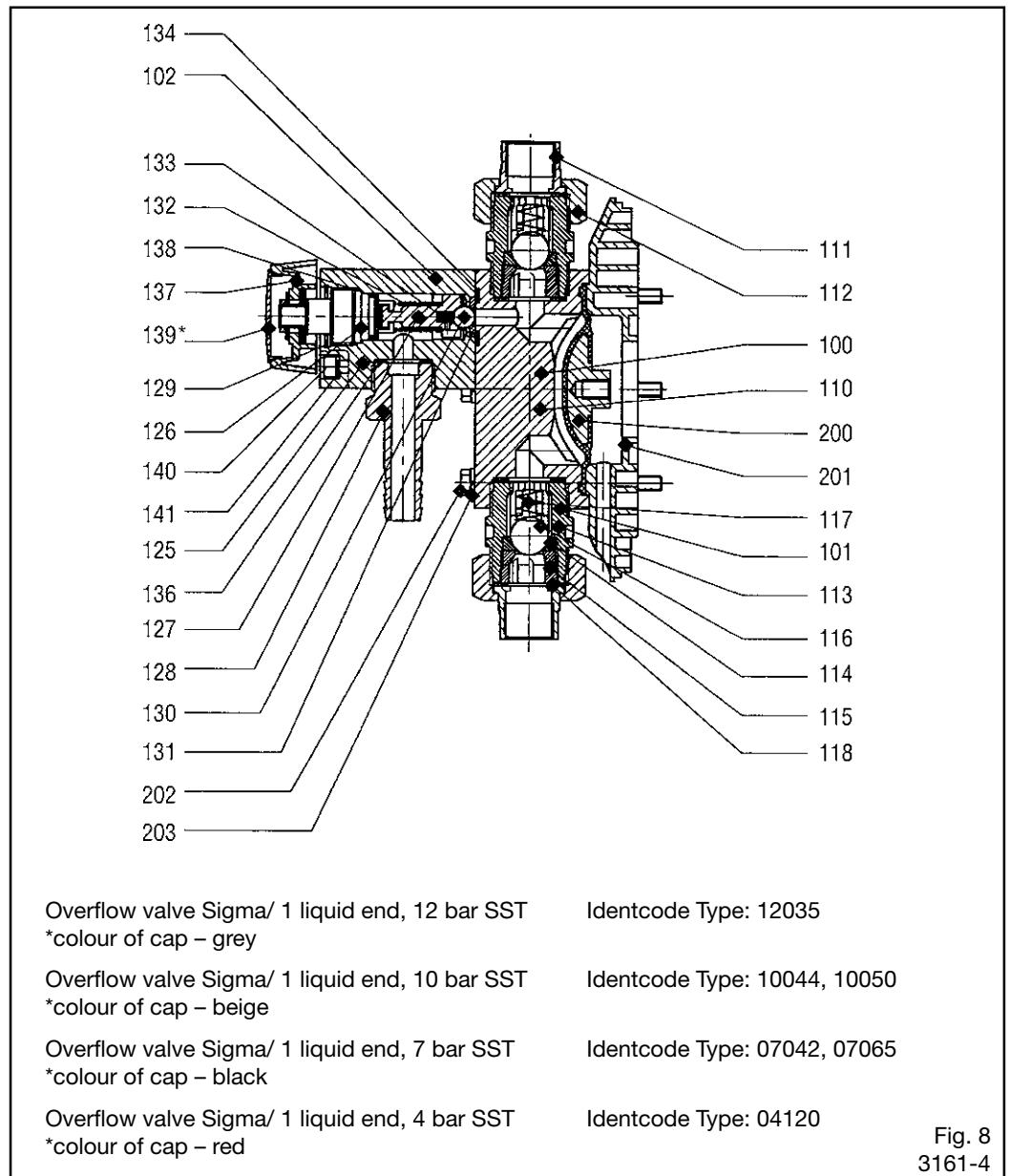

**NOTICE**

- Knob item 139 must be turned in clockwise direction as far as it will go "close".
- The bypass line must always be closed and must be routed back into the supply tank. Connection via hose connection item 128.
- Minimal overflow can occur in the bypass line when the valve operates close to the overpressure function.

The bleeder function is achieved by turning knob item 139 in counterclockwise direction as far as it will go "open": Priming aid for starting up pump against pressure. The force of spring item 132 relieves ball item 130 which is controlled by the lower spring force of bleeder spring item 133.



**NOTICE**

Once the pump has primed, turn knob item 139 in clockwise direction as far as it will go "close"! The pump can now be placed into operation.

### Technical data

Corresponding to the type of pump, overflow valves are available for pressure stages  $p_{nom}$  4, 7, 10 and 12 bar with  $(1.05 \dots 1.15) \times p_{nom}$  opening pressure.

### Material in contact with metered medium

Material version	Liquid end	Suction/discharge connector	Seals	Balls	Springs	Integrated overload valve
PVT	PVDF	PVDF	PTFE	Ceramic / glass	Stainless steel 1.4301	PDFE/Viton®
SST	Stainless steel 1.4571/1.4404	Stainless steel 1.4581	PTFE	Stainless steel 1.4404	Stainless steel 1.4301	Stainless steel /Viton®

Viton® is a registered trademark of DuPont Dow Elastomers.

### Use for intended purpose/Use not for intended purpose

#### Use for intended purpose

To protect the motor and gear unit against impermissible overpressure caused by the metering pump.

If the pump is the only pressure generator in the system, the overflow valve will also protect the system automatically.



#### NOTICE

- The ceramic ball and ball seat of the overflow valve are wearing parts. Slight leakage can occur at the safety valve after a prolonged period of operation. The ball and ball seat should be replaced if leaks occur.
- The bypass line must always be connected and must be routed back into the supply tank.

#### Use not for intended purpose

To protect the system from impermissible overpressure which has other causes than the pressure generated by the metering pump.

The pump must not be operated without the bypass line connected.

The bypass line must not be connected in the intake line (the bleeder function will no longer be guaranteed). The bypass line must be routed back into the supply tank.



#### DANGER

When carrying out maintenance work on the overcurrent valve, pay attention to the tensioning state of the pressure spring item132! Wear safety goggles!

## 2.2.6 Diaphragm rupture sensor

### Function:

Monitors the seals in the working diaphragm. This liquid end can continue to function for a short period in emergency mode, i.e. full operating pressure, no leakage, even after diaphragm rupture.

### Design and function description (see Fig. 9)

Liquid ends with diaphragm rupture sensors comprise a standard liquid end (item 100) a working diaphragm (item 200) and an auxiliary diaphragm (item 148) The auxiliary diaphragm is positioned between the back plate (item 201) and the interim plate (item 147) and forms a sealed compartment together with the working membrane (item 200).

The leak tightness of the working diaphragm, Item 200, is monitored with a diaphragm failure detector, Item 104, that triggers a contact signal in the event of diaphragm failure so that the pump is stopped in the S1Ca and the diaphragm failure is indicated on a LCD.

The liquid end can continue to operate in emergency mode, i.e. full operating pressure, no leakage, even after diaphragm rupture, until the diaphragm has been replaced. We offer two versions of the S3Ca with diaphragm rupture sensor:

- After a working diaphragm rupture, the pump stops and an „error“ message/diaphragm sensor signal is given.
- After a working diaphragm rupture, the pump will continue to run. An „error“ message/ electrical signal is given.

A function plug is supplied which allows the pump to continue operating after a fault has occurred (diaphragm rupture, failure of the diaphragm rupture sensor).



**NOTICE**

- In the case of the S1Ba, the customer should install a diaphragm rupture signal monitor and/or ensure that the pump will stop after a diaphragm rupture.
- In the event of diaphragm failure, a contact signal is triggered as from 2 bar system backpressure.
- Exact pump delivery can no longer be guaranteed after failure of the working diaphragm.
- The auxiliary diaphragm, Item 148, is a wearing part and must be replaced after failure of the working diaphragm. The diaphragm rupture sensor lens should be replaced after every diaphragm rupture.

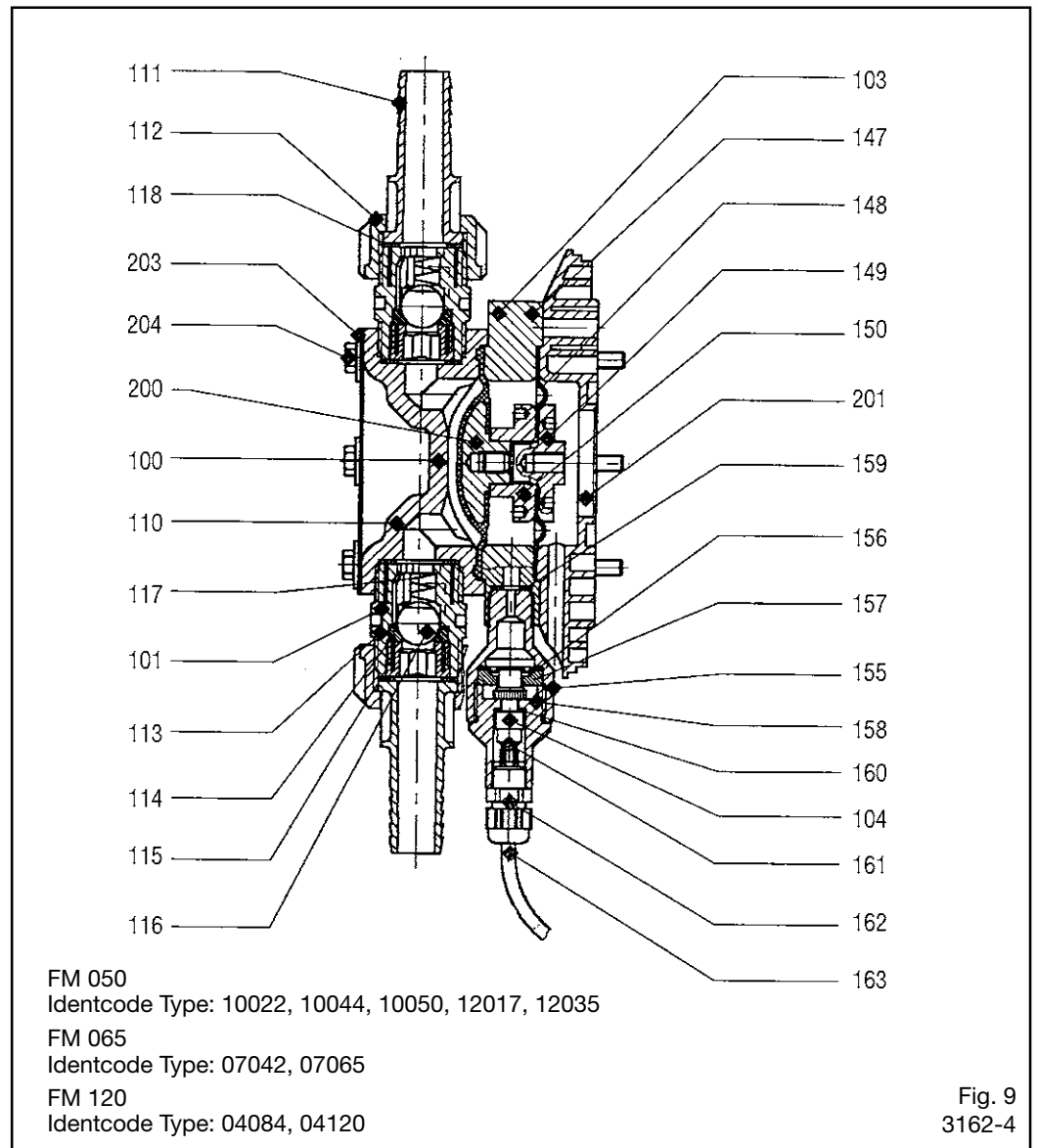

Fig. 9  
3162-4

**Material in contact with metered medium**

Liquid end:	Parts of diaphragm failure monitor in contact with medium	
	Lens, seals Item 148, 156, 159	Intermediate disc Item 147, intermediate bush Item 150
PVDF Stainless steel 1.4571	PTFE PTFE	PVDF PVDF

**Electrical data for the diaphragm breakage sensor**

30 V DC/1 A      or      125 V AC/0.6 A      or      250 V AC/0.3 A

The diaphragm sensor is a N/C relay.

**NOTICE**

**Before commencing operation, install the provided diaphragm breakage sensor together with the gasket (Item159) and make the electrical connections.**

**IMPORTANT**

- For safety reasons it is advisable to connect a safe low voltage (e.g. EN 60335-1 (SELV)).
- The cable priority is arbitrary.

### 3 Technical data

#### 3.1 Technical data Sigma/ 1

##### 3.1.1 Capacity data

###### Technical data S1Ba at 50 Hz operation

Pump type Sigma/	Feed rate at maximum back pressure			Max. stroke rate	Suction lift	Admissible priming pressure suction side	Connection suction / discharge side	Shipping weight
	bar	l/h	ml/ stroke					
12017 PVT	12	17	4.0	73	7		3/4"-10	8
12017 SST	12	17	4.0	73	7		3/4"-10	11
12035 PVT	12	35	4.0	143	7		3/4"-10	8
12035 SST	12	35	4.0	143	7		3/4"-10	11
10050 PVT	10	50	4.0	200	7		3/4"-10	8
10050 SST	10	50	4.0	200	7		3/4"-10	11
10022 PVT	10	22	5.1	73	6		3/4"-10	8
10022 SST	10	22	5.1	73	6		3/4"-10	11
10044 PVT	10	44	5.1	143	6		3/4"-10	8
10044 SST	10	44	5.1	143	6		3/4"-10	11
07065 PVT	7	65	5.1	200	6		3/4"-10	8
07065 SST	7	65	5.1	200	6		3/4"-10	11
07042 PVT	7	42	9.7	73	3		1"-15	8.5
07042 SST	7	42	9.7	73	3		1"-15	12.5
04084 PVT	4	84	9.7	143	3		1"-15	8.5
04084 SST	4	84	9.7	143	3		1"/15	12.5
04120 PVT	4	120	9.7	200	3		1"-15	8.5
04120 SST	4	120	9.7	200	3		1"-15	12.5

## Technical data

### Technical data S1Ba at 60 Hz operation and S1Ca

Pump type Sigma	Feed rate at maximum back pressure		Max. stroke rate	Suction lift	Admissible priming pressure suction side	Connection suction / discharge side	Shipping weight		
	bar	psi						l/h	gph min.
12017 PVT	12	174	20	5	88	7		3/4"-10	8
12017 SST	12	174	20	5	88	7		3/4"-10	11
12035 PVT	12	174	42	11	172	7		3/4"-10	8
12035 SST	12	174	42	11	172	7		3/4"-10	11
10050 PVT	10	145	60 (50*)	16	240 (200*)	7		3/4"-10	8
10050 SST	10	145	60 (50*)	16	240 (200*)	7		3/4"-10	11
10022 PVT	10	145	26	7	88	6		3/4"-10	8
10022 SST	10	145	26	7	88	6		3/4"-10	11
10044 PVT	10	145	53	14	172	6		3/4"-10	8
10044 SST	10	145	53	14	172	6		3/4"-10	11
07065 PVT	7	102	78 (65*)	21	240 (200*)	6		3/4"-10	8
07065 SST	7	102	78 (65*)	21	240 (200*)	6		3/4"-10	11
07042 PVT	7	102	50	13	88	3		1"-15	8.5
07042 SST	7	102	50	13	88	3		1"-15	12.5
04084 PVT	4	58	101	27	172	3		1"-15	8.5
04084 SST	4	58	101	27	172	3		1"-15	12.5
04120 PVT	4	58	144 (120*)	38	240 (200*)	3		1"-15	8.5
04120 SST	4	58	144 (120*)	38	240 (200*)	3		1"-15	12.5

\* Values for S1Ca

### Materials in contact with chemicals

Material version	Liquid end	Suction/ discharge connector	Seals	Balls	Springs	Integrated overload valve
PVT	PVDF	PVDF	PTFE	Ceramic / glass	Stainless steel 1.4301	PDFE/Viton®
SST	Stainless steel 1.4571/1.4404	Stainless steel 1.4581	PTFE PTFE	Stainless steel 1.4404	Stainless steel 1.4301	Stainless steel/Viton®

### Temperature specifications

Permissible storage temperature: -10 to +50 °C

Permissible ambient temperature: -10 to +40 °C

### Temperature compatibility (medium temperature) of materials

Material:	Long-term at max. backpressure:	Short-term, max. 15 min. at max. 2 bar
PVT	65 °C	100 °C
SST	90 °C	120 °C

The specified temperatures (see above) can be exceeded temporarily, e.g. for sterilisation or flushing with hot water.

### Accuracy

Under constant conditions and in minimum stroke length of 30 % corresponding to following notes, the reproducibility of the metered quantity is better than ±2 %.

All specifications refer to metered quantities with water at 20 °C and correct installation of the metering pump.

### 3.1.2 Dimensions Sigma/ 1

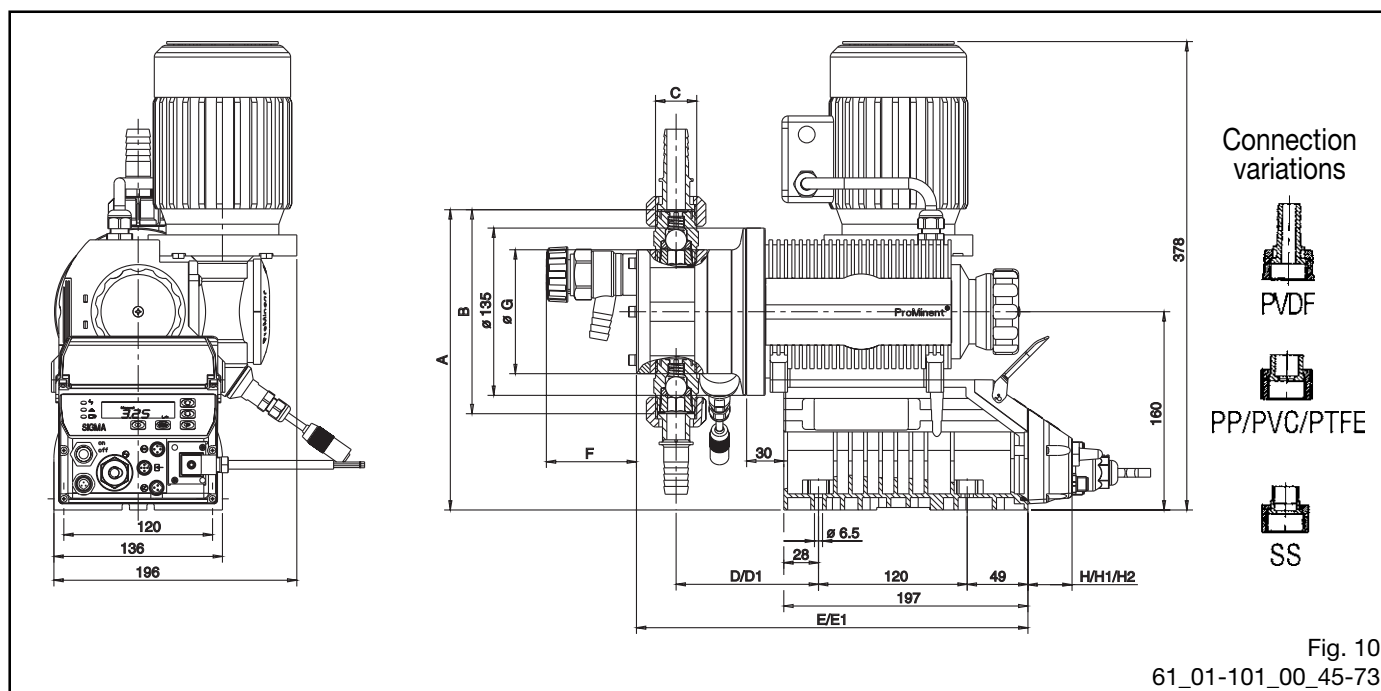

Fig. 10  
61\_01-101\_00\_45-73

#### Dimensions in mm

Typ	Connector	A	B	C	D	DI**	E	EI**	F	Ø G	H#	H1##	H2###
Sigma 12017, 12035, 10022, 10044 10050, 07065 PVT	DN 10	233	147	G 3/4 A	90	110	275	295	84	96	3	36	3
Sigma 12017, 12035, 10022, 10044, 10050, 07065 PVT - ÜV-A	DN 10	233	147	G 3/4 A	90	110	277	297	84	96	3	36	3
Sigma 12017, 12035, 10022, 10044, 10050, 07065 SST	DN 10	233	146	G 3/4 A	89	109	275	295	88	96	3	36	3
Sigma 12017, 12035, 10022, 10044, 10050, 07065 SST - ÜV-A	DN 10	233	146	G 3/4 A	89	109	275	295	88	96	3	36	3
Sigma 07042, 04084, 04120 PVT	DN 15	242	165	G 1 A	95	115	285	305	73	122	3	36	3
Sigma 07042, 04084, 04120 PVT - ÜV-A	DN 15	242	165	G 1 A	95	115	296	316	73	122	3	36	3
Sigma 07042, 04084, 04120 SST	DN 15	242	164	G 1 A	94	114	285	305	88	122	3	36	3
Sigma 07042, 04084, 04120 SST - ÜV-A	DN 15	242	164	G 1 A	94	114	285	305	88	122	3	36	3

Dimensions with

\*\* diaphragm rupture sensor,

# cover, basic model

## Controller cover,

### Controller cover (pacing relay)

3.1.3 Dimension sheet Sigma/ 1 with right-hand liquid end

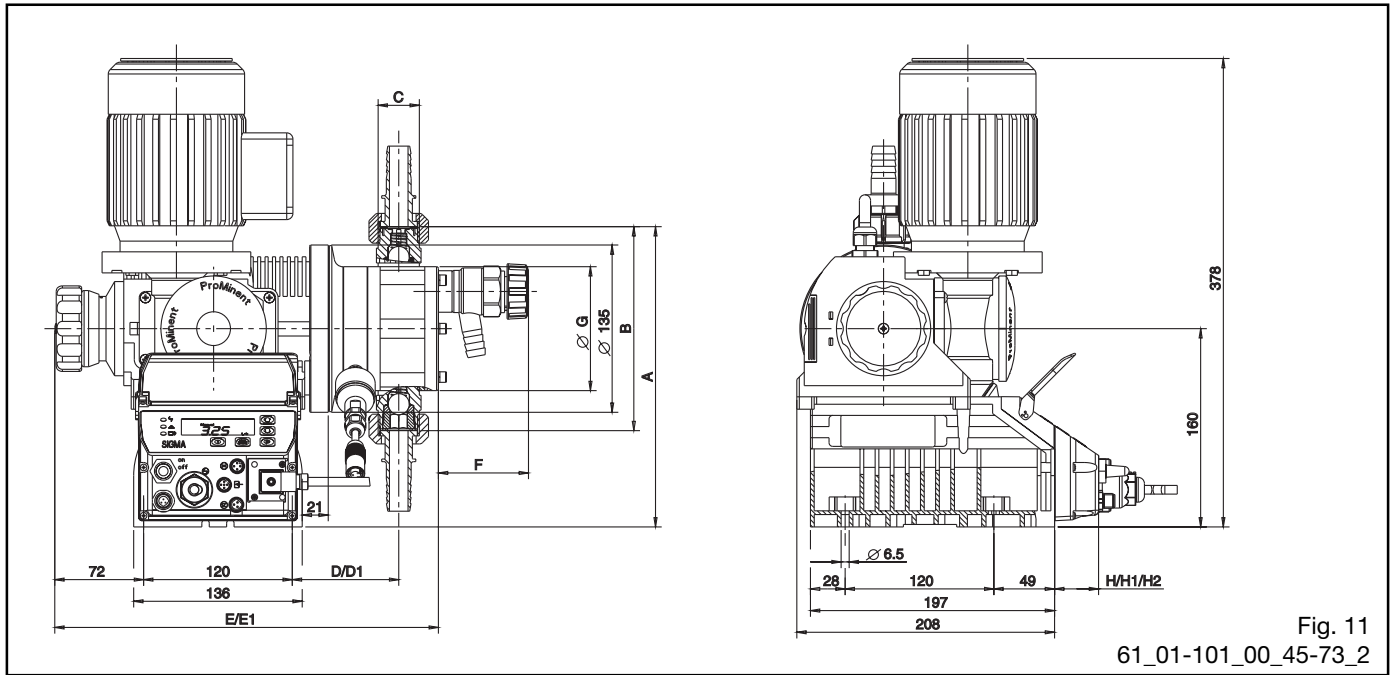

Dimensions in mm

Typ	Connector	A	B	C	D	DI**	E	EI**	F	Ø G	H#	H1##	H2###
Sigma 12017, 12035, 10022, 10044 10050, 07065 PVT	DN 10	233	147	G 3/4 A	61	81	269	289	84	96	3	36	3
Sigma 12017, 12035, 10022, 10044, 10050, 07065 PVT - UV-A	DN 10	233	147	G 3/4 A	61	81	271	291	84	96	3	36	3
Sigma 12017, 12035, 10022, 10044, 10050, 07065 SST	DN 10	233	146	G 3/4 A	60	80	269	289	88	96	3	36	3
Sigma 12017, 12035, 10022, 10044, 10050, 07065 SST - UV-A	DN 10	233	146	G 3/4 A	60	80	269	289	88	96	3	36	3
Sigma 07042, 04084, 04120 PVT	DN 15	242	165	G 1 A	66	86	279	299	73	122	3	36	3
Sigma 07042, 04084, 04120 PVT - UV-A	DN 15	242	165	G 1 A	66	86	290	310	73	122	3	36	3
Sigma 07042, 04084, 04120 SST	DN 15	242	164	G 1 A	65	85	279	299	88	122	3	36	3
Sigma 07042, 04084, 04120 SST - UV-A	DN 15	242	164	G 1 A	65	85	279	299	88	122	3	36	3

Dimensions with  
 \*\* diaphragm rupture sensor,  
 # cover, basic model  
 ## Controller cover,  
 ### Controller cover (pacing relay)

### 3.1.4 Dimension sheet Sigma/ 1 with left-hand liquid end

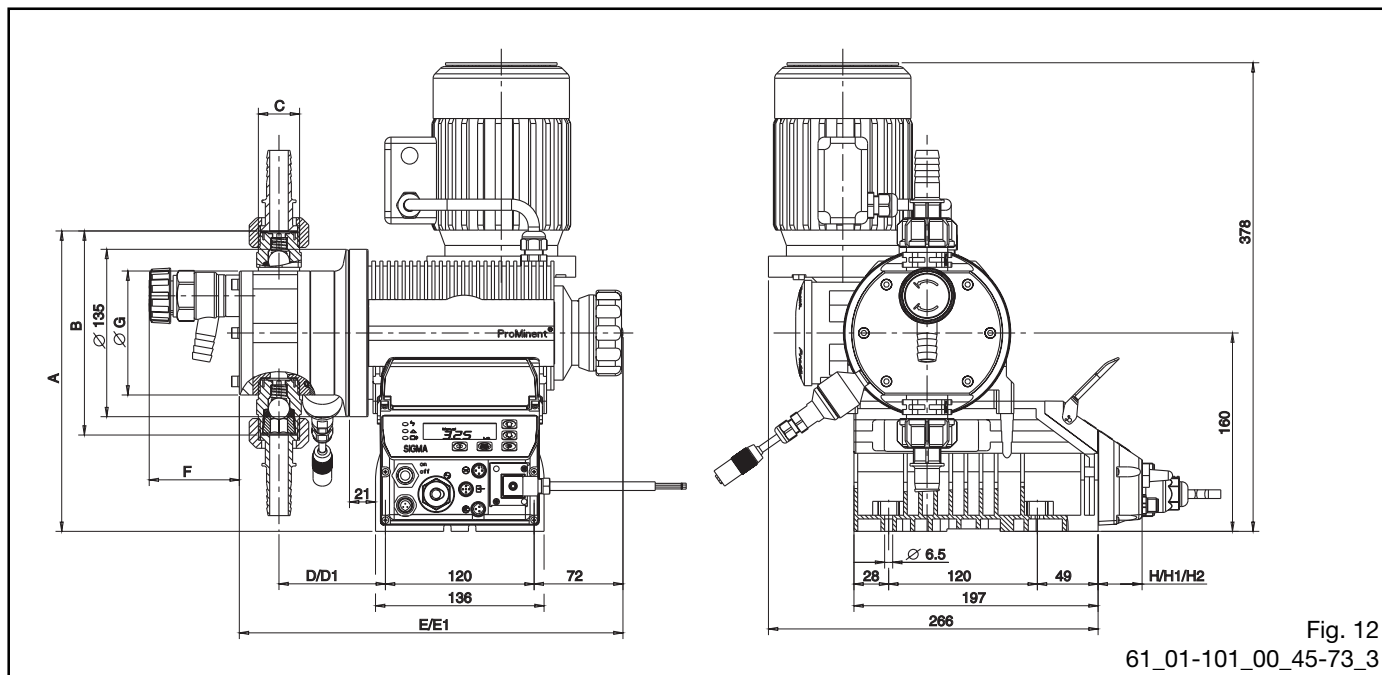

Fig. 12  
61\_01-101\_00\_45-73\_3

Table of variable dimensions, see 3.1.3  
Dimensions in mm

### 3.1.5 Motor data

#### Electrical Data

Motors:						Identcode characteristic
3 ph IP 55	230 V/400 V	50 Hz	0.09 kW	0.7/0.39		S
3 ph IP 55	265 V/460 V	60 Hz	0.09 kW	0.68/0.38		S
1 ph Wechselstrom	230 V	50/60 Hz	0.09 kW			M
1 ph Wechselstrom	115 V	60 Hz	0.09 kW			N
3 ph EXe oder EXde	230 V/400 V	50 Hz	0.09 kW			L
3 ph EXe oder EXde	230 V/400 V	60 Hz	0.09 kW			P
3 ph IP 55	230 V/400 V	50/60 Hz	0.09 kW	.....		R Version with external fan 1 PH 230 v; 50/60 Hz and PTC
1 ph IP 55	230 V	50/60 Hz	0.09 kW	.....		V Three phase motor with integrated speed changer

For more details you can request the motor specification sheets. Custom motors and/or custom motor flanges are available on request.

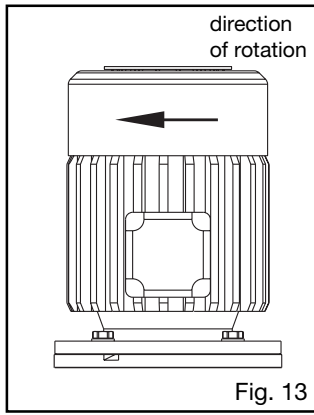

**Fuse data**



**NOTICE**

- The motors are not fuse-protected. Fit a motor circuit breaker.
- When connecting the motor, make sure that it rotates in the correct direction

**Protection against accidental contact and moisture (IP)**

Motor: IP 55 DIN EN 60034-5 (in accordance with DIN VDE 0470 Part 1, corresponds to EN 60529 and IEC 529).

**External fan**

External fan for speed controlled motor with external fan and temperature monitor:  
Note information in “General operating instructions for ProMinent® metering pumps and hydraulic accessories”.

**3.1.6 Stroke actuator drive mechanism**

230 V ± 10 %	50/60 Hz	11.7 W
115 V ± 10 %	60 Hz	11.7 W

Cf. “Appendix” for terminal connection diagram.

**3.1.7 Stroke adjuster drive mechanism**

230 V ± 10 %	50/60 Hz	6.5 W
115 V ± 10 %	60 Hz	6.5 W

Cf. “Appendix” for terminal connection diagram.

**3.1.8 Electrical data, stroke sensor “S1Ba”**

**a) Reed contact (Identcode characteristic “Stroke sensor”: 1, 2)**

- Pin 1 (white) = 4.5 V to 24 V, max. 10 mA
- Pin 2 (brown) = OUT, open collector, 24 V, 20 mA
- Pin 3 (green) = GND
- Pulse width (low) ≥ 4 ms (depending on gearbox and power frequency)

Blue	-
Brown	+

**b) Stroke sensor (Identcode characteristic “Stroke sensor”: 3)**

5-25 V DC, Namur type and/or DIN 19234, zero volt design.

Rated voltage: 8 V DC ( $R_i \sim 1 \text{ k}\Omega$ )

Power consumption:

- Active surface, uncovered > 3 mA
- Active surface, covered < 2 mA

Rated switching distance: 1.5 mm

The monitor/feeder must be capable of evaluating current changes in order to indicate diaphragm rupture!

Enclosure rating: EEx ia II C T 6 / EEx ib II CT 6

With a suitable feed device the sensor can be used in explosive areas.

**3.1.9 Electrical data, pacing relay “S1Ba”**

Contact load: max. 42 V / 100 mA.

Contact duration Standard: 100 ms (adjustable)

**3.1.10 Sound intensity level**

The sound intensity level is < 70 dB (A)  
at maximum stroke, maximum stroking rate, maximum back pressure (water) in accordance with DIN EN 12639 (noise measurement in fluid pumps)

## 4 Start-up/Maintenance



### NOTICE

Observe the safety notes provided in Section 1.

### 4.1 Start-up

All general guidelines in the accompanying "General operating instructions ProMinent® motordriven metering pumps and hydraulic accessories" apply.

### 4.2 Maintenance



### NOTICE

After loosening the liquid end screws (e.g. to change the valves or diaphragm), the screws must be retightened crosswise to the specified tightening torque.

#### What requires maintenance?

- Secure fit of liquid end screws.
- Secure fit of metering lines (intake and delivery sides).
- Secure fit of head valve and intake valve.
- Leakage hole at end disc for moisture (indicates possible diaphragm failure).
- Operate pump continuously for a short period of time in order to check whether it delivers correctly.

#### Maintenance intervals

General recommendation for maintenance intervals - every 3 months.

Shorter intervals are recommended if operated under load conditions (e.g. continuous operation).

The metering diaphragm is a wearing part whose service life is dependent on following parameters:

- System backpressure.
- Operating temperature.
- Properties of medium to be metered.

The service life of the diaphragm is restricted in the case of abrasive media. In such cases, it is recommended to check the diaphragm more frequently and to install a diaphragm failure monitor.

### 4.3 Replacement of wearing parts

Replacing diaphragm (see exploded diagrams in appendix!)



### NOTICE

Flush liquid end first in the case of hazardous media. For this purpose, force water or a suitable flushing agent through the intake connection of the liquid end with a wash bottle.

- ▶ Set stroke length to zero with the pump running. Switch off pump.
- ▶ Release the six screws holding the liquid end, detach liquid end together with screws.
- ▶ Release diaphragm from the push rod by jolting in counterclockwise direction and unscrew.
- ▶ Screw on new diaphragm until it is firmly seated on the push rod. Mount the dosing head with screws such that the suction connection lies at the bottom (observe the flow through direction / arrow marks on the valves). Switch on pump. Set stroke length to 100% and turn in screws then tighten crosswise to  $4.5 \pm 0.5$  Nm. Check pump for leaks at max. pressure.

**IMPORTANT**

The tightening torque of the liquid end screws should be rechecked after 24 hours of operation.

The tightening torques of the liquid end screws should be checked every 3 months for the PVT material version.

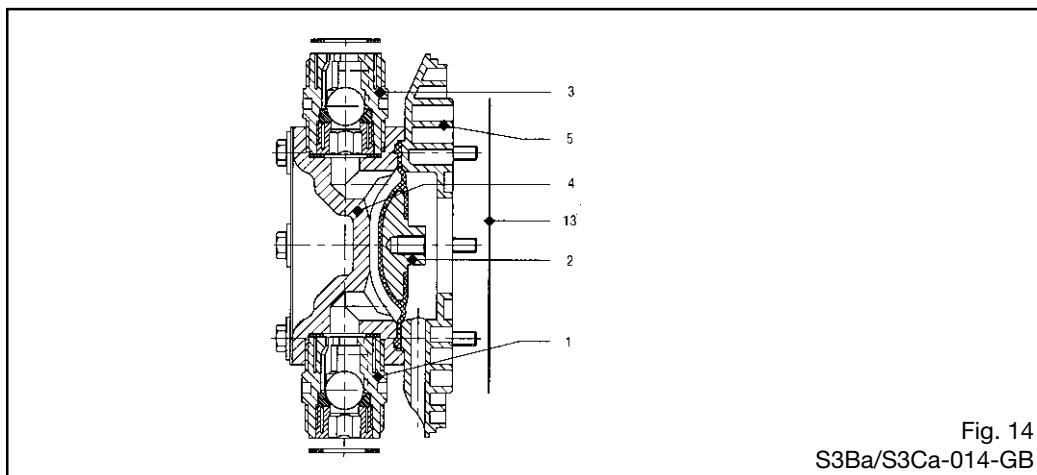

Fig. 14  
S3Ba/S3Ca-014-GB

**GUIDELINE ON VALVE INSTALLATION (DN 25 ball valve)**

In the case of suction problems during installation, place the valves on a firm surface and tap the PTFE ball seat disk lightly with a brass rod and a hammer weighing about 300 g. Let the valves such in the wet state.

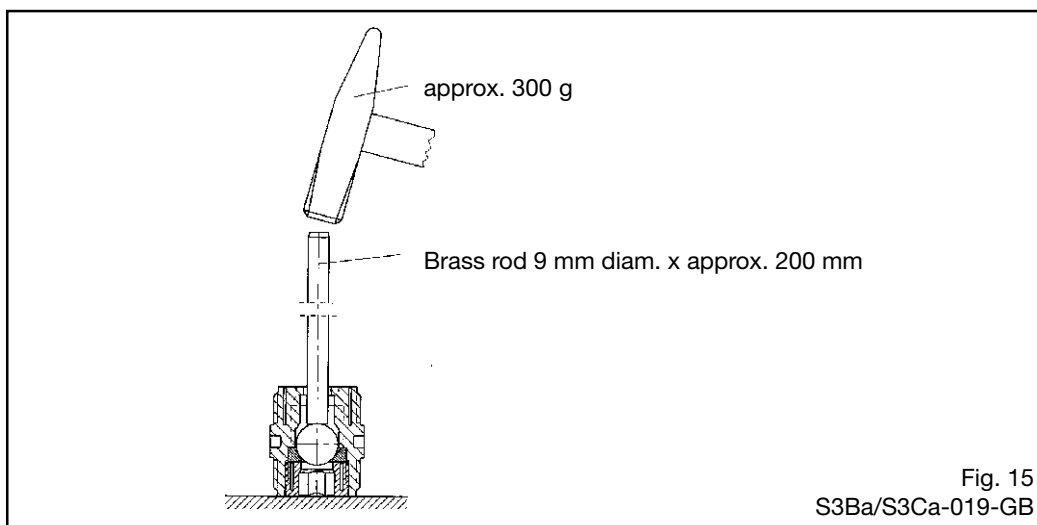

Fig. 15  
S3Ba/S3Ca-019-GB

**IMPORTANT**

- The suction and pressure valves of the metering head and the overcurrent valve have a hard ball seat. If suction problems with the pump or leakage at the overcurrent valve are encountered, first clean the ball and the ball seat disc.
- For media containing particles larger than 0.3 mm it is absolutely essential to install a filter in the suction line.

## 5 Features of the S1Ca metering pumps

### 5.1 Function description, motors

The pump has an integrated electronic overload cut-out in all versions. This responds as soon as the maximum admissible power consumption is reached and stops the motor.

- ▶ If the motor stops due to a system overload the electronic controller detects the fault and transmits a message which is displayed on the display panel and at the pump.
- ▶ The fault signal can be cancelled by pressing the „P“ key, altering the level for a brief period at the pause input (switch function) or by reconnecting the pump to the mains.



#### **NOTICE**

**If the pump has been switched off by the thermal overload protection, check that it is not permanently overloaded.**

#### **IMPORTANT**

- S1Ca-Pump types - in general 60 Hz performance data applies (because 60 Hz internal operation).
- The controller changes over to stop-and-go mode at low stroke frequencies! This takes place at stroke frequencies below 1/3 of the maximum stroke frequency. This function is designed to ensure sufficient cooling of the motor and low stroke frequencies.

#### **S1Ca**

Type: 100 – 230 V ± 10 %, 50/60 Hz

	bei 100 V	bei 230 V
Nominal output	130 W	130 W
Nominal current	2.2	1.2 A
Peak current (in operation)	3 A	3 A
Making peak current	8 A	16 A
Fuse, internal*	3.15 AT (1.5kA)	3.15 AT (1.5kA)

\* Only genuine fuses of ProMinent, item no. 732414, may be used!

### 5.2 Function description, controller

- Operating modes* Operating modes are selected using the MODE menu (depending upon identity code, some operating modes may be absent).
- “Analogue” operating mode:** (Identity code, control variant: analogue)  
The stroke rate is controlled via an analogue electrical signal via the “external control” terminal. Signal processing is pre-selected at the controller.
- “Manual” operating mode:**  
The stroke rate is controlled manually via the controller.
- “Contact” operating mode:**  
This operating mode offers the opportunity to make fine adjustments with small increase/decrease factors. Dosing can be activated by a pulse via the “external control” terminal or by a semiconductor element. With the “pulse control” option it is possible to pre-set a feed quantity (batch) or number of strokes (factor 0.01 to 99.99) via the control unit.
- “Batch” operating function:**  
This operating mode offers the option of working with larger transfer factors (up to 65535). Metering can be triggered by pressing the P key or a pulse from the “external control” terminal via a contact or semiconductor element. A batching quantity or number of strokes can be pre-selected via the control unit.
- “PROFIBUS®” mode:** (Identity code, control variant: PROFIBUS®)  
This operating mode provides the option of controlling the pump via the PROFIBUS® (see “Supplementary instructions for ProMinent® gamma/ L and ProMinent® Sigma versions with PROFIBUS®”).
- Functions* The following functions can be selected using the SET menu:
- “Calibrate” function:**  
The S1Ca can be operated in all operating modes including in calibrating mode. The corresponding continuous displays can show the actual feed quantity or the feed rate. Calibration is maintained within the stroke frequency range 0-180 strokes/ min. Calibration is also maintained when a stroke frequency is altered up to  $\pm 10\%$ .
- “Auxiliary frequency” function:**  
It is possible to set a stroke rate in the SET menu, which may be activated via the “external control” terminal. This auxiliary frequency overrides all other pre-set stroke rate frequencies.
- “Flow” function:**  
Stops the S1Ca when the flow is insufficient. In the SET menu, the number of failed strokes is entered after which the pump will be turned off.
- The following functions are available as standard:
- “Float switch” function:**  
Information on the liquid level in the feed chemical container is transmitted to the S1Ca. This option requires the installation of a 2-stage float switch. This is connected to the “float switch” terminal.
- “Pause” function:**  
The S1Ca can be stopped by remote control via the “external control” terminal. The “pause” function operates only via the “external control” terminal.
- The following functions are activated by keystrokes:
- “Stop” function:**  
The S1Ca can be stopped by pressing the STOP/START key without disconnecting from the mains power supply.
- “Prime” function:**  
Priming (short term feed at maximum frequency) is activated by pressing both arrow keys at the same time (in “stroke rate” permanent display).

*Optional relay*     The S1Ca has two connection options.

**“Fault indicating relay” option:**

In the event of fault signals, warning signals or float switch activation signals, connects an electrical circuit to trigger alarm sirens etc. The relay is retrofitted via an aperture in the power end.

**“Fault indicating and pacing relay” option:**

In addition to the fault indicating relay the pacing relay can make a contact with every stroke. The relay is retrofitted via an aperture in the power end.

*Function and error indicators*

The operating and error status is shown via the three LEDs and the “error” indicator on the LCD (see also section 9):

*LCD indicator*

If a fault occurs “error” will appear along with an additional fault warning.

*LED indicator*

**Operating indicator (green)**

This indicator is lit as long as the S1Ca is operating correctly. It goes out briefly with every stroke.

**Warning indicator (yellow)**

This warning light appears if the S1Ca electronics detect a situation that could lead to a fault, e.g. “liquid levels low 1st stage”.

**Warning indicator (red)**

This warning light appears if a fault occurs, e.g. “liquid levels low 2nd stage”.

**Hierarchy of operating modes, functions and fault statuses**

The different operating modes, functions and fault statuses each have a differing effect on whether and how the S2Ca functions. These effects are given below:

- 1. Prime**
- 2. Fault, stop, pause**
- 3. Auxiliary frequency**
- 4. Manual, analogue, contact, batch**

i.e.

1. “Prime” can be activated in “stroke rate” permanent display in any pump status (as long as it is operable)
2. “Fault”, “stop” and “pause” stop all system parts up to “prime”.
3. The stroke rate of the “auxiliary frequency” always overrides the stroke rates of the operating modes listed in point 4.

### 5.3 Sockets, symbols and wiring diagram

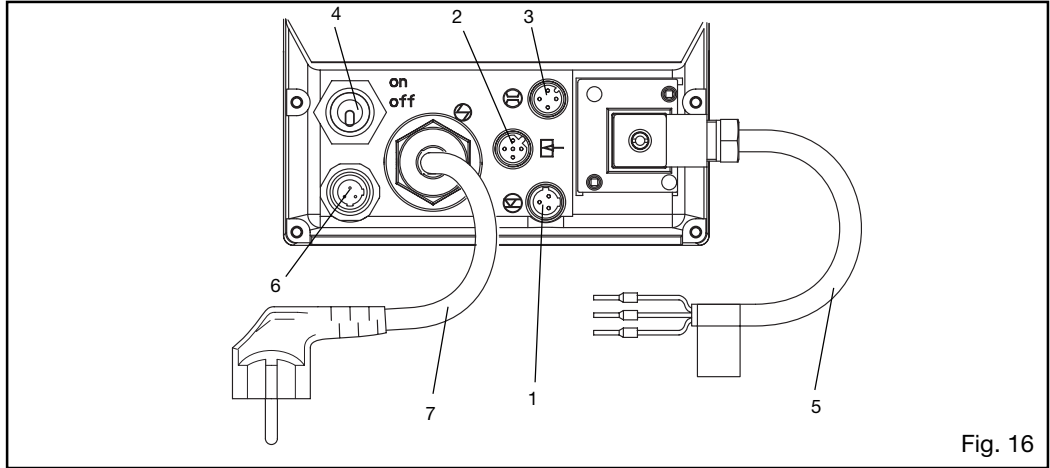





Fig. 16

-  (1) Socket for two-stage float switch with advance warning and de-activate function (with function plug\*, not illustrated)
-  (2) External socket for contact or analogue controller with zero volts deactivation via pause function (with function plug\* - not illustrated)
-  (3) Metering monitor socket for connection of ProMinent® metering monitor
- (4) Mains switch (1-pin)
- (5) Relay cable (fault indicating or pacing relay)
- (6) Socket for diaphragm rupture sensor
-  (7) Mains lead with plug

\*Must be plugged in unless cable attached.

#### Relay input specification

##### Fault indicating relay:

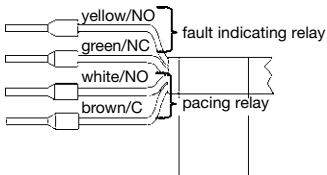

N/C fault indicating relay - the relay closes immediately after the power is switched on and opens in the event of a fault.

N/O fault indicating relay, the relay closes in the event of a fault.

- Contact load: 200 000 switch cycles at 250 V AC, 2 A (ohmic consumption)

Use suitable interference suppression (e.g. RC glands) when connecting inductive loads.

##### Pacing relay:

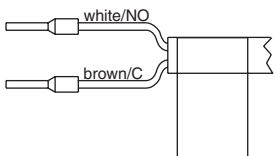

- Contact load: max 42 V DC/AC, max 100 mA  
max 50 x 10<sup>6</sup> switch cycles (at 10 V, 10 mA).

### Wiring diagram

View of cable connectors from front

#### Float switch cable

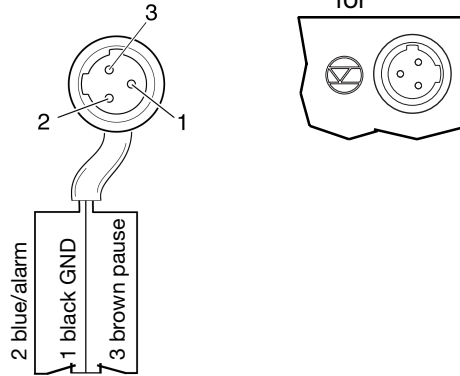

Blue and black open  
-> alarm signal  
Brown and black open  
-> alarm signal + pump stops

#### Universal signal cable (5-core)

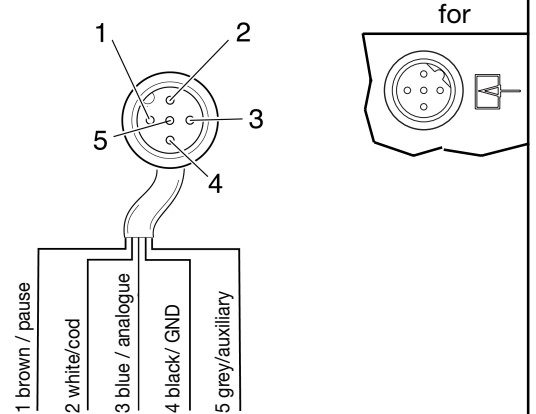

Pause function:  
brown and black closed  
-> pump metering  
brown and black open  
-> alarm + pump stopped

External/contact:  
white and black closed  
-> start contact for pump  
(note pause function:  
brown and black closed?)

Analogue:  
blue, black  
-> analogue output 0/4-20 mA  
(note pause function:  
brown and black closed?)

Auxiliary frequency:  
grey and black closed  
-> pump metering at pre-set stroking rate

#### Metering monitor cable

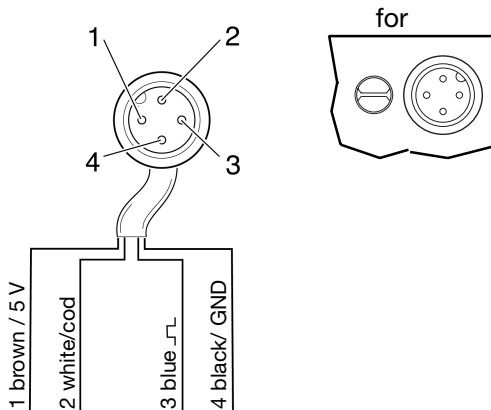

1 brown / 5V  
2 white/cod  
3 blue  
4 black/ GND

#### Diaphragm rupture cable

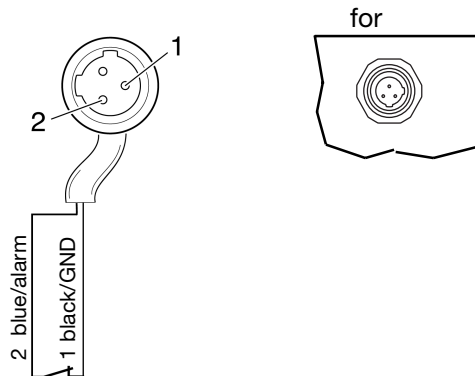

Contact open -> alarm  
-> pump stops with controller type 0

#### External/contact cable (2 core)

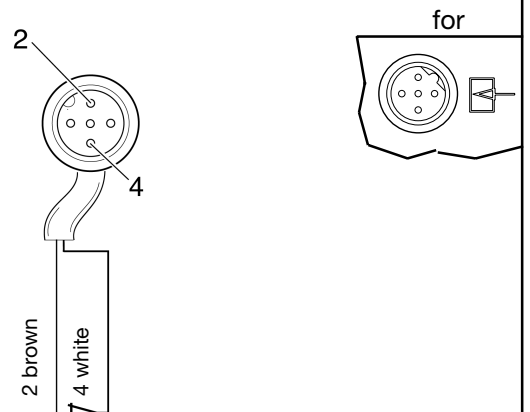

Contact closed -> metering stroke

### Technical data, external contact

Semi-conductor switch elements (e.g. transistors in open-collector circuits) or contactors (relays) with a residual voltage of  $-0.7\text{ V}$  can be used as input switch elements.

#### Controller type 0 (see identity code)

Pin 1 = Pause input (activating function)

Voltage at open contacts: approx.  $5\text{ V}$

Input resistance:  $10\text{ k}\Omega$

Controller: – zero volts contact (approx.  $0.5\text{ mA}$ )  
– semi-conductor (residual voltage:  $< 0.7\text{ V}$ )

Pin 2 = Contact input

Voltage at open contacts: approx.  $5\text{ V}$

Input resistance:  $10\text{ k}\Omega$

Controller: – zero volts contact (approx.  $0.5\text{ mA}$ )  
– semi-conductor (residual voltage:  $< 0.7\text{ V}$ )

Min. contact duration:  $20\text{ ms}$

Max. pulse frequency:  $25\text{ pulses/s}$

Pin 3 = unused

Pin 4 = GND

Pin 5 = Auxiliary input

Voltage at open contacts: approx.  $5\text{ V}$

Input resistance:  $10\text{ k}\Omega$

Controller: – zero volts contact (approx.  $0.5\text{ mA}$ )  
– semi-conductor (residual voltage:  $< 0.7\text{ V}$ )

#### Controller type 1 (see identity code)

Pin 1 = Pause input (activating function)

Voltage at open contacts: approx.  $5\text{ V}$

Input resistance:  $10\text{ k}\Omega$

Controller: – zero volts contact (approx.  $0.5\text{ mA}$ )  
– semi-conductor (residual voltage:  $< 0.7\text{ V}$ )

Pin 2 = Contact input (not active during analogue operation)

Voltage at open contacts: approx.  $5\text{ V}$

Input resistance:  $10\text{ k}\Omega$

Controller: – zero volts contact (approx.  $0.5\text{ mA}$ )  
– semi-conductor (residual voltage:  $< 0.7\text{ V}$ )

Min. contact duration:  $20\text{ ms}$

Max. pulse frequency:  $25\text{ pulses/s}$

Pin 3 = Identical to input\*

Input load: approx.  $120\ \Omega$

Pin 4 = GND

Pin 5 = Auxiliary input

Voltage at open contacts: approx.  $5\text{ V}$

Input resistance:  $10\text{ k}\Omega$

Controller: – zero volts contact (approx.  $0.5\text{ mA}$ )  
– semi-conductor (residual voltage:  $< 0.7\text{ V}$ )

\* The metering pump makes its first metering stroke at approx.  $0.4\text{ mA}$  ( $4.4\text{ mA}$ ) and starts continuous operation at approx.  $19.2\text{ mA}$ .

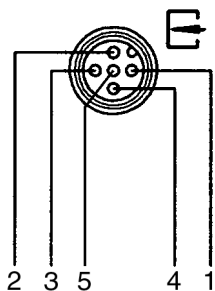

### Block circuit diagram S1Ca

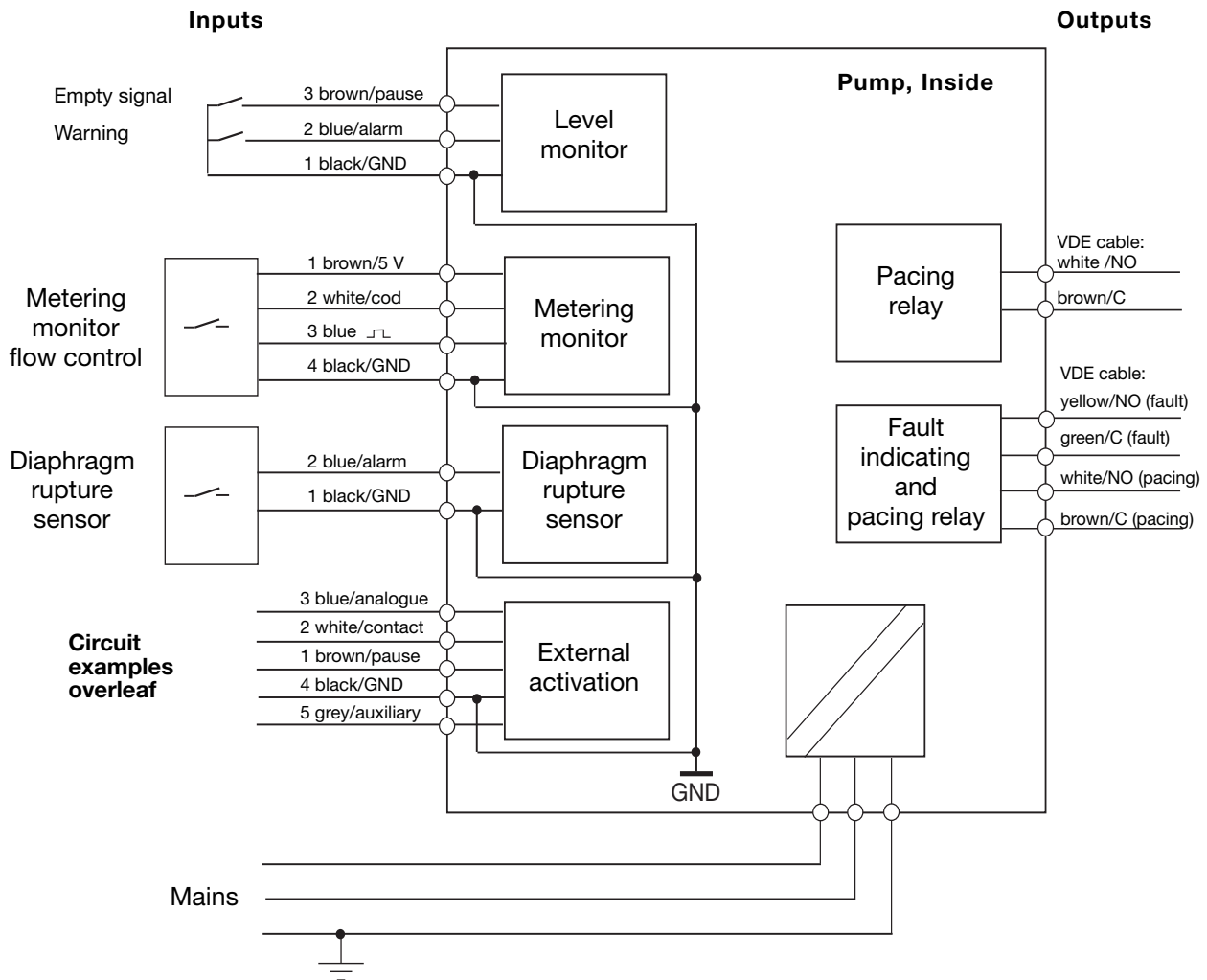

**Circuit examples: universal signal cable**  
**by customer      Cable      Pump, inside**

„External contact“ function  
 (ProMinent® external/contact cable)  
 two-core

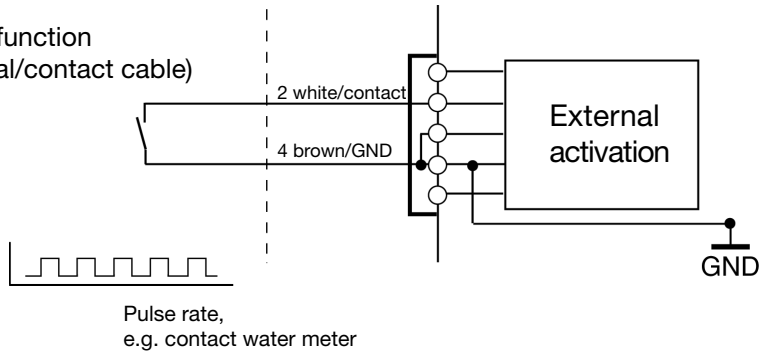

„External contact“ function  
 (ProMinent® universal signal cable)  
 five-core

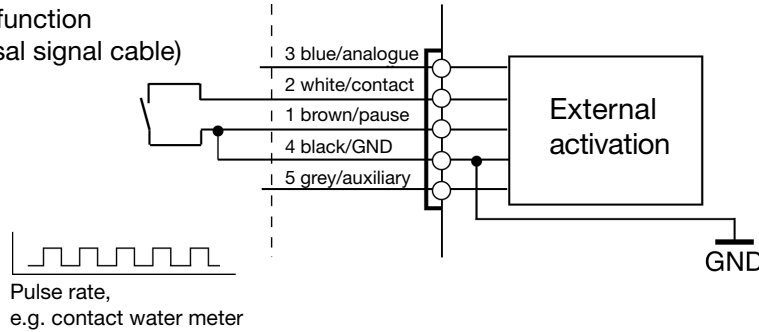

„Pause“ function

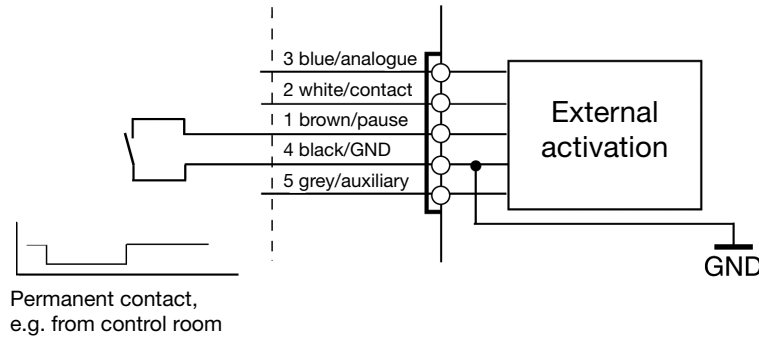

„Auxiliary frequency“ function

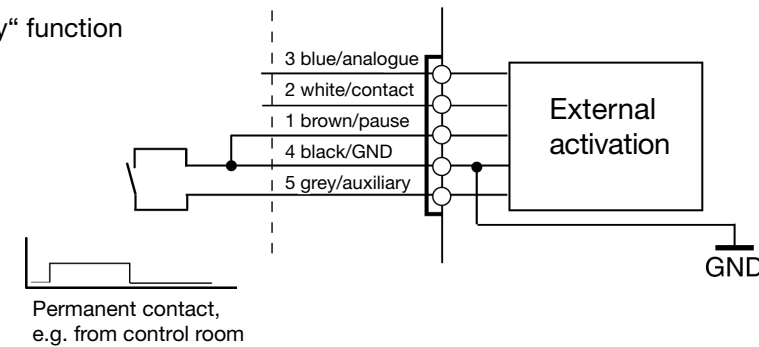

„External analogue“ function

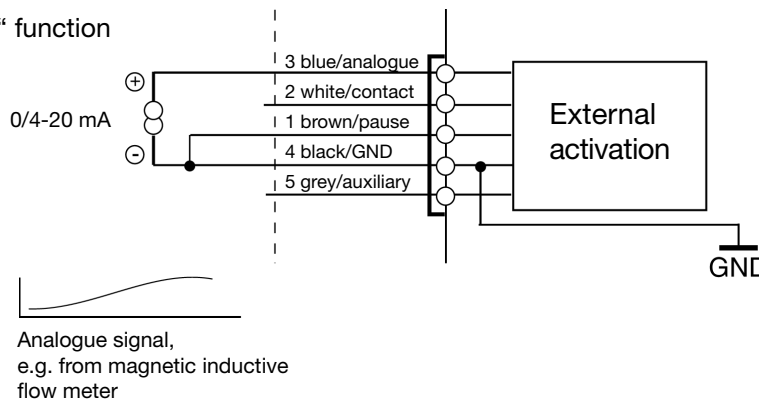



**NOTICE**

- The universal signal cable, the external/contact cable and the level monitor cable should not be less than 1.20 m long, otherwise cable recognition will fail.

**5.4 Retrofitting relays (not by PROFIBUS® version)**

**Delivery range:**

- 1 relay circuit set with 2 screw fasteners
- 1 relay cable set with socket
- 1 seal

*Press-out relay opening*



**WARNING**

**Disconnect the S1Ca from the mains power supply and rinse liquid end before commencing work (see section 10)!**



**NOTICE**

**When preparing the opening, ensure that the punch is not forced through the entire pump base!  
Pump circuits may become damaged.**

- ▶ Place the S1Ca on a firm surface with the relay opening press-out section at the top (see fig. 17)
- ▶ Place a punch (dia. 8-15 mm) in the centre of the relay opening press-out section , and strike briefly and sharply with a hammer (approx. 250 g)
- ▶ If necessary clean up the edges of the opening
- ▶ Remove the pressed out section from the S1Ca

*Inserting the relay component*

- ▶ Hold the relay component with your right hand gripping the left and right hand edges of the relay cover, and tilt the front end slightly to the left (see fig. 18)
- ▶ Push the relay component through the relay opening, holding the upper corner of the lower edge against the guide rail on the pump base, until the contact of the relay component has reached the controller contact. (test: can you still move the end of the circuit back and forth?)
- ▶ Gently push the relay component right into the opening
- ▶ Screw the relay cover firmly onto the housing using the screws provided
- ▶ Insert the relay cable plug seal into the relay cover and screw on the plug (see fig. 20)
- ▶ The pump is generally programmed ex-factory to „drop-out action alarm relay“ and – if fitted – „pull-up action clock pulse generator relay“. If a switching function is required, the pump can be reprogrammed at the Heidelberg plant (not necessary by PROFIBUS®-version).

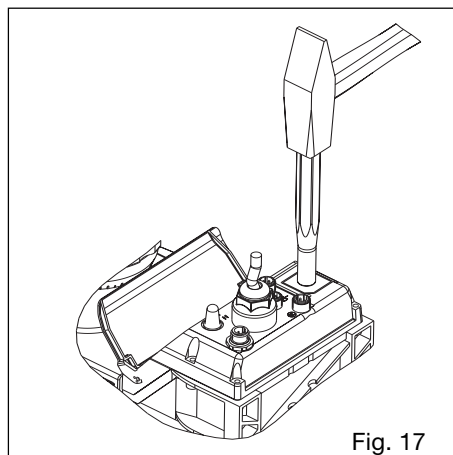

Fig. 17

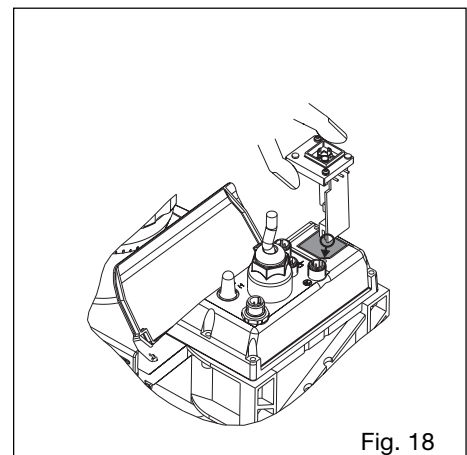

Fig. 18

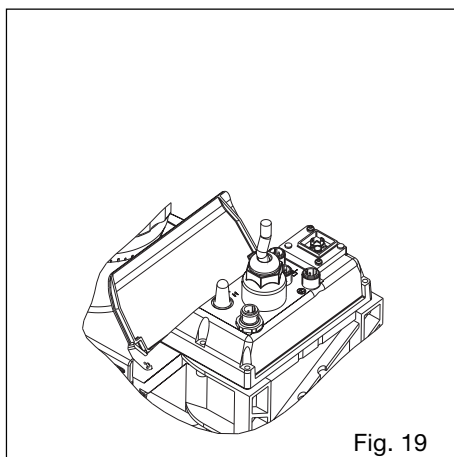

Fig. 19

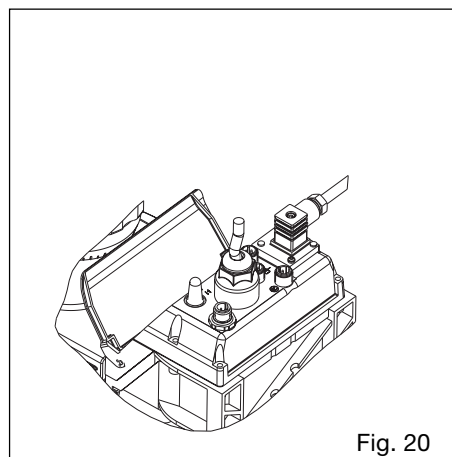
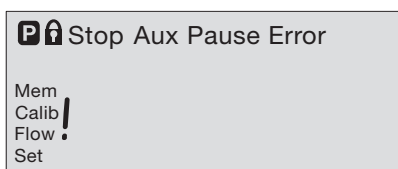

Fig. 20

## 6 Control elements

Please acquaint yourself with the S1Ca control elements with the help of the “control elements and key functions” overview!

*Indicators* The LCD display supports the operation and setting of the S1Ca with a range of indicators:



The indicators are interpreted as follows:

<b>Symbol for P key:</b>	The S1Ca is in settings mode.
<b>Close symbol:</b>	In a continuous display: lock (if code has been set). In settings mode: indicates access to code menu.
<b>Stop:</b>	The S1Ca has been stopped using the STOP/START key.
<b>Aux:</b>	The S1Ca is pumping at the auxiliary frequency. In AUX menu: the S1Ca is in the AUX menu.
<b>Pause:</b>	The S1Ca has been stopped using the “pause” function (external).
<b>Error:</b>	A fault has occurred and the pump has been stopped.
<b>Mem:</b>	An additional “memory” function has been set in the “contact” and “batch” operating modes. In CNTCT or BATCH menus (“mem” flashes): the memory function can be set.
<b>Calib:</b>	The S1Ca is in the CALIB menu. In a continuous display (“calib” flashes): Deviation from the stroking rate from the value at the time of the calibration by more than 10 percent (e.g. in the case of a stroke length of 40% when it has been set to less than 30% or more than 50%).
<b>Flow:</b>	The S1Ca is in the FLOW menu.
<b>Set:</b>	The S1Ca is in the SET menu.
<b>Exclamation mark:</b>	The number of strokes reached is above the maximum value (99999) that can be shown in the LCD display.

### **IMPORTANT**



When calibrated, the S1Ca displays the feed rate and the feed capacity in l and/or in l/h or in gal and/or g/h.

## 7 Settings

### IMPORTANT

- Open out the fold-out page following the title page fully! There you will find the overviews “control elements and key functions” and “operating settings diagram”.
- If no keys are pressed within a period of 1 minute, the S1Ca will return to a continuous display.

### Basic information for setting up the S1Ca

 = Settings option  
 = flashes

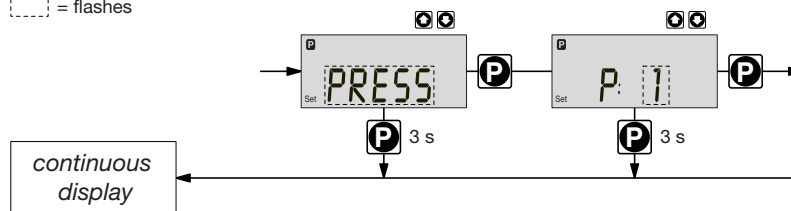

#### Confirm entries

Press the P key briefly;  
 you will automatically move to the next menu option or to a continuous display.

#### Exit menu option without confirming

Press the P key for 3 s:  
 The entry is cancelled and you will return to a continuous display.

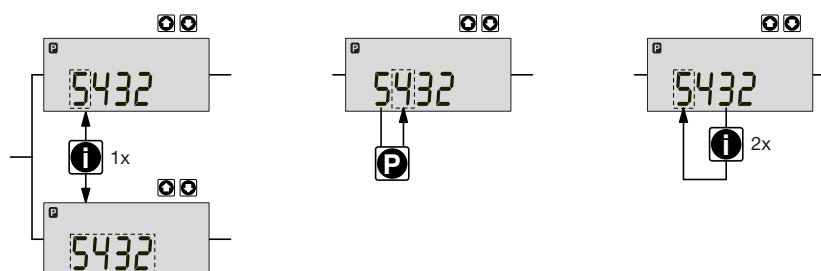

#### Incremental change of a value

Press the i key 1x;  
 you can toggle between altering the digits of a value (“change individual digits” = standard) or incremental alteration of a value (“change a figure”).

#### Change adjustable values

Press UP or DOWN arrow key;  
 The flashing digit or figure will start to increase or decrease incrementally.

#### Confirm adjustable values

For “change individual digits”: confirm each digit using the P key. When the last digit has been confirmed you will automatically move to the next menu option or to a continuous display.  
 For “change a figure”; press the P key 1x; you will simultaneously move to the next menu option or to a continuous display.

#### Correct wrongly set digits

Press the i key 2x;  
 you will go back to the first digit.

## 7.1 Check adjustable values

Before setting up the S1Ca you can check the current settings of adjustable values:

Press the i key (“i” as in “info”) when the S1Ca is in continuous display mode (There is no P key symbol in the LCD display).

Each time you press the i key you will see a different continuous display. The number of continuous displays depends upon the identity code, the selected operating mode and the connected accessories (see overview “continuous displays”).

## 7.2 Change to settings mode

If you hold down the P key for 2 seconds in any continuous display, the S1Ca will change to the settings mode.

If CODE 1 is set, the code must be entered after pressing the P key.

The following menu options appear first in the settings mode (see also overview “operating/ settings diagram”):

- MODE menu
- CODE menu (optional)
- SET menu
- CLEAR window

In order to adapt the S1Ca to your process requirements you must:

1. Select the operating mode in the MODE menu.
2. Adjust settings to this operating mode in the SET menu.

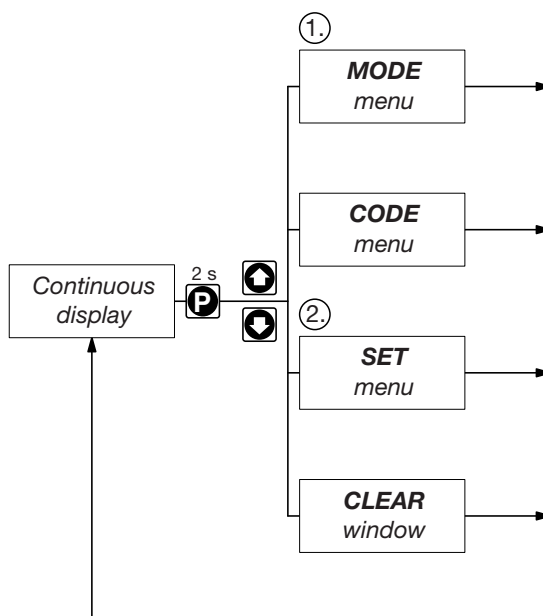

### 7.3 Select operating mode (MODE menu)

The following operating modes are selected via the MODE menu (depending upon identity code, some operating modes may be absent):

- Manual: for operation by hand  
(Identity code, control variant: manual, standard option)
- Analogue: for electronic control  
(Identity code, control variant: analogue current)
- Contact: for contact operation  
(Identity code, control variant: external 1:1 / external with pulse control)
- Batch: for batch operation  
(Identity code, control variant: external with pulse control)

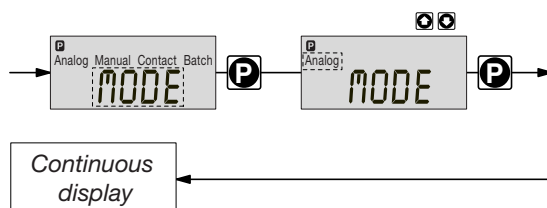

### 7.4 Settings for operating mode (SET menu)

In the SET menu you can adjust various settings depending upon the selected operating mode.

The following programmable function settings menus appear in all operating modes:

- Calibrate (CALIB menu)
- Auxiliary frequency (AUX menu)
- Flow (FLOW menu, available only if flow monitor is connected)

See also section 7.5!

Further settings menus depend upon the selected operating mode.

#### 7.4.1 Settings for “manual” operating mode

There are no other settings menus in the overall SET menu for the “manual” operating mode apart from those described in 7.5.

#### 7.4.2 Settings for “analogue” operating mode (ANALG menu)

In addition to those settings menus described in 7.5, there is an additional ANALG menu in the overall SET menu for the “analogue” operating mode.

The stroke rate is controlled by an analogue electrical signal via the “external control” terminal. You can select three signal-processing methods:

- 0 - 20 mA: at 0 mA the S1Ca does not operate  
at 20 mA the S1Ca operates at 180 strokes/min.  
Between these two extremes the stroke rate is proportional to the electrical signal.

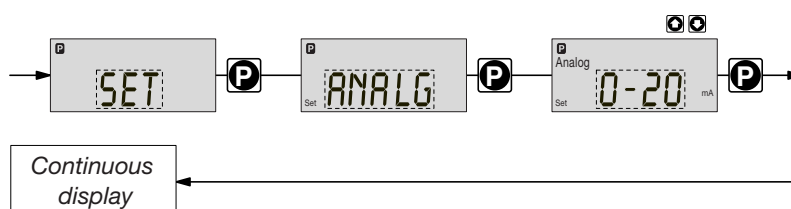

- 4 - 20 mA: at 4 mA the S1Ca does not operate  
at 20 mA the S1Ca operates at 180 strokes/min.  
Between these two extremes the stroke rate is proportional to the electrical signal.  
For signals of below 3.8 mA a fault will be detected and the S1Ca will stop (e.g. cable break).
- Curve: In the “curve” processing mode you can programme the S1Ca ratios.  
There are 3 options available:
  - ----- = straight line
  - ---\ --- = lower band
  - ---/\ --- = upper band

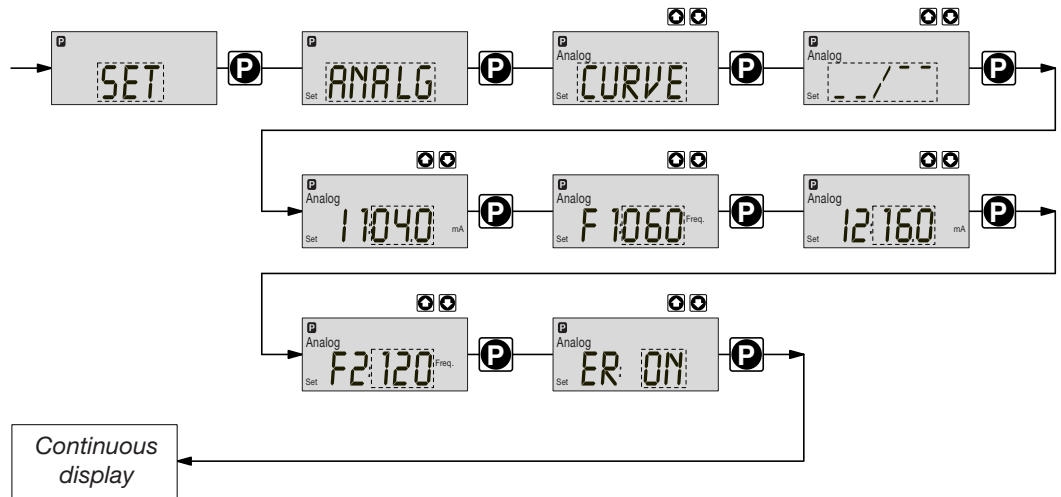

**Straight line:**

The following symbol appears in the LCD display: ----- .  
You can enter any stroke frequency ratio for the S2Ca in proportion to the electrical signal.  
You must enter two points P1 (I1, F1) and P2 (I2, F2). F1 is the stroke rate at which the pump should operate at current I1: the straight line and the ratio are fixed accordingly:

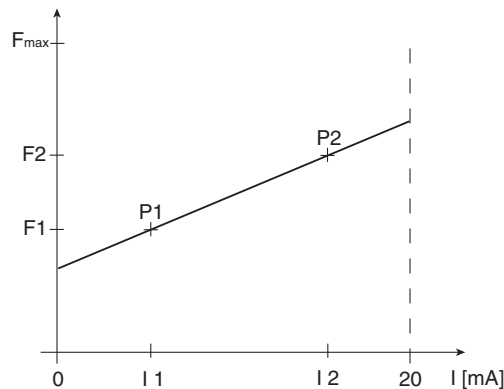

Fig. 21

**IMPORTANT**

Draw a diagram like the one above - with values for (I1, F1) and (I2, F2) - in order to set the S1Ca to your required stroke rate!

**Lower/upper band:**

This processing mode allows you to control a pump via an electrical signal as shown in the diagrams below.

**Lower band**

e.g. Alkali pump

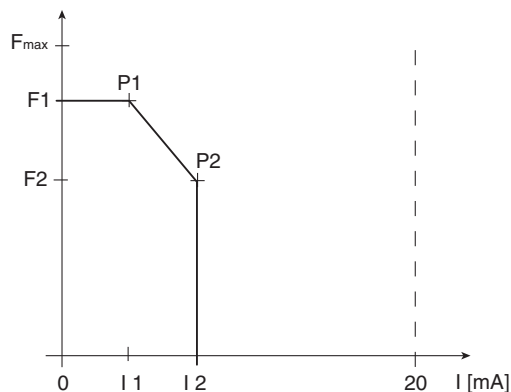

Fig. 22

**Upper band**

e.g. acid pump

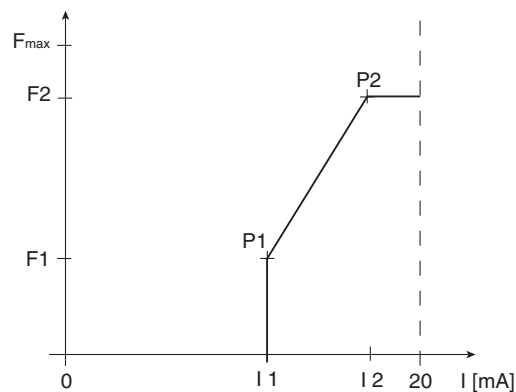

Fig. 23

**Lower band:**

The symbol  $\text{---} \setminus \text{---}$  appears in the LCD display. The S1Ca will operate below I1 at F1. Above I2, the S1Ca ceases to operate. Between I1 and I2 the stroke rate is between F1 and F2, proportional to the signal current.

**Upper band:**

The signal  $\text{---} / \text{---}$  appears in the LCD display. The S1Ca will cease to operate below I1. Above I2, the S1Ca will operate at F2. Between I1 and I2 the stroke rate between is F1 and F2, proportional to the signal current.

The smallest processable difference between I1 and I2 is 4 mA.

*Error processing*

In the "ER" (error) menu option you can activate an error processing function for the "curve" mode. An error message appears for signals below 3.8 mA and the S1Ca stops.

**7.4.3 Settings for "contact" operating mode (CONTCT menu)**

In addition to those settings menus described in 7.5, there is an additional CONTCT in the overall SET menu for the "contact" operating mode.

The operating mode "contact" allows you to activate a single stroke or a series of strokes. The strokes can be activated by a pulse or via the "external control" terminal. This operating mode is intended to transfer input pulses into a reduction (fraction) or small increase in strokes.

**NOTICE**

The factor resets to "1" if you change to a different operating mode.

In the “contact - identity code: external with external pulse control” you can enter the number of pulses after which a stroke should be carried out. “Contact - identity code: external with external pulse control” is intended for small dosing quantities.

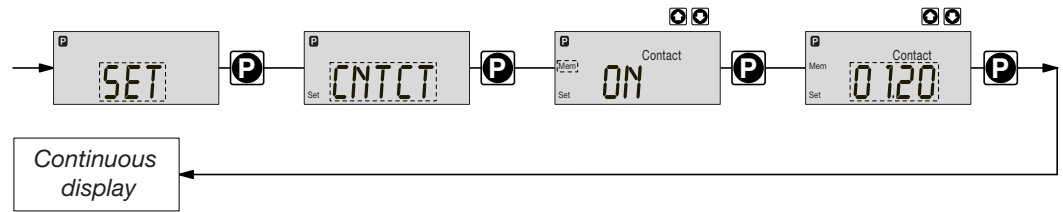

The number of strokes per pulse depends upon the factor, which you can enter. This allows you to vary to a certain extent the input pulses by a factor of 1.01 to 99.99 and/or reduce by a factor of 0.01 to 0.99:

“Number of strokes activated = factor x number of input pulses”

*Examples*

	Factor	Pulse (sequential)	Stroke number (sequential)
<b>Increase</b>	1	1	1
	2	1	2
	25	1	25
	99.99	1	99.99
	1.50	1	1.5 (1 / 2)
	1.25	1	1.25 (1 / 1 / 1 / 2)
<b>Reduction</b>	1	1	1
	0.50	2	1
	0.10	10	1
	0.01	100	1
	0.25	4	1
	0.40	2.5 (3 / 2)	(1 / 1)
	0.75	1.33 (2 / 1 / 1)	(1 / 1 / 1)

*Explanation of increase*

At a factor of 1 For every 1 pulse, 1 stroke is activated  
 At a factor of 2 For every 1 pulse, 2 strokes are activated  
 At a factor of 25 For every 1 pulse, 25 strokes are activated

*Explanation of decrease*

At a factor of 1 After 1 pulse, 1 stroke is activated  
 At a factor of 0.5 After 2 pulses, 1 stroke is activated  
 At a factor of 0.1 After 10 pulses, 1 stroke is activated  
 At a factor of 0.75 After 2 pulses, 1 stroke is activated, then after 1 pulse, 1 stroke is activated, then after 2 pulses, 1 stroke is activated etc.

**IMPORTANT**

If a remainder occurs when the factor is processed, the S1Ca counts up the remainder values. When the sum reaches or exceeds “1” the S1Ca will activate a stroke. This ensures that the stroke number corresponds exactly to the factor throughout the dosing operation .

The number of input pulses which have not been processed are stored by the S1Ca in the stroke memory. When the STOP/START key is pressed or the “pause” function is activated, the stroke memory is deleted (this can be avoided using the “memory” extension function, see below).

You can optimally adapt the S1Ca to the respective process, e.g. in connection with contact water meters.

### “Memory” extension function

The “memory” extension function can be optionally activated (“mem” appears in the LCD display). When “Memory” is activated the S1Ca adds any strokes which could not be carried out up to the maximum capacity of the stroke buffer – 65535 strokes. If this maximum capacity is exceeded the pump will register a fault.

## 7.4.4 Settings for “batch” operating mode (BATCH menu)

In addition to those settings menus described in 7.5, there is an additional BATCH menu in the overall SET menu for the “batch” operating mode.

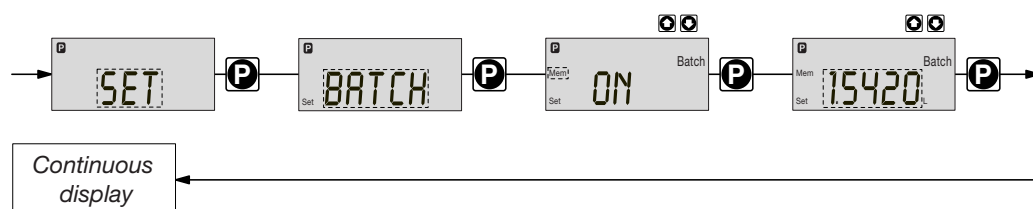

The “batch” operating mode is a variant of the “contact” operating mode (see 7.4.3). You can pre-select a stroke number (no breaks, whole numbers only from 1 to 65535) as well as a feed quantity (batch). To switch between entries for “stroke number” and “feed quantity” press the *i* key 1x in the corresponding menu option (see also overview “operating/settings diagram”, fold-out page).

The “batch” operating mode is intended for large dosing quantities.

Metering can be actuated by pressing the P-key or via a pulse from the “external control socket”.

The number of input pulses which have not been processed are stored by the S1Ca in the stroke memory. The stroke buffer is limited to the batch size when memory is not activated (- with “Memory” at 65535 strokes). You can delete it by switching to a different operating mode.

### “Memory” extension function

The “memory” extension function can be optionally activated (“mem” appears in the LCD display). When “Memory” is activated the S1Ca adds any strokes which could not be carried out up to the maximum capacity of the stroke buffer – 65535 strokes. If this maximum capacity is exceeded the pump will register a fault.

## 7.5 Settings for programmable functions (SET menu)

The following programmable function settings menus appear in all operating modes:

- Calibrate (CALIB menu)
- Auxiliary frequency (AUX menu)
- Flow (FLOW menu, available only if flow monitor is connected)

### 7.5.1 Settings for “calibration” function (CALIB menu)

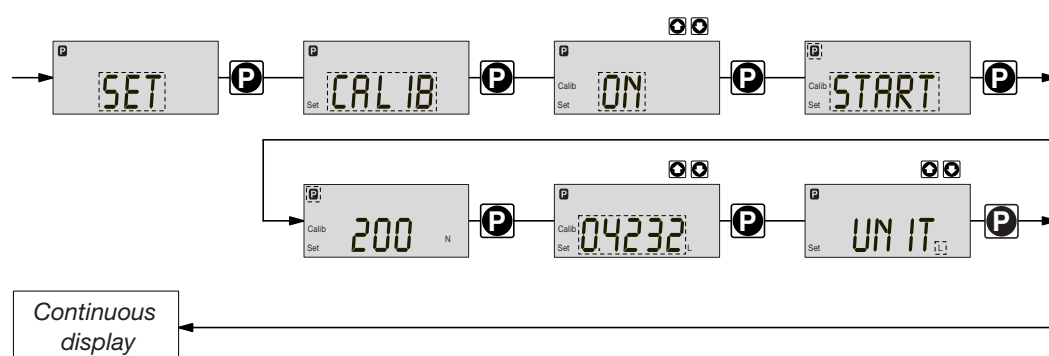

The S1Ca can also run in calibration mode. The corresponding continuous displays show the current dosing quantities or the feed rate.

The calibration is retained in the event of a change of the set stroke length by up to  $\pm 10$  percent (if the stroke length is set to 40% the range is 30% to 50%). If the stroke length is changed by more than  $\pm 10$  percent the yellow warning light lights up, the permanent display flashes and the flashing “Calib” indicator appears.

**IMPORTANT**

- Do not go below 30 % stroke length (SEK type: 50 %). This will significantly affect accuracy of calibration.
- Calibration becomes increasingly accurate the more strokes made by the S1Ca during calibration (recommended: at least 200 strokes).



**WARNING**

**If using a hazardous feed chemical, the following setting instructions ensure adequate safety precautions have been taken!**

*Calibration*

- ▶ Insert the suction tube into a measuring cylinder containing the feed chemical - the discharge tubing must also be correctly installed (operating pressure,...!)
- ▶ Suck up the feed chemical (press both arrow keys at the same time) when the suction tube is empty
- ▶ Note the liquid level in the measuring cylinder and the stroke length
- ▶ Select the CALIB menu and go the first menu option using the P key
- ▶ Select “ON” using an arrow key and change to the next menu option using the P key
- ▶ To commence calibration, press the P key. The S1Ca starts to pump and displays the number of strokes (“STOP” appears at regular intervals)
- ▶ After a sufficient number of strokes, stop the S1Ca with the P key
- ▶ Calculate the dosed quantity (difference between the original quantity and the quantity remaining)
- ▶ Enter this quantity in the next menu option and then change to the following menu option by pressing the P key.
- ▶ Select the unit (“L” or “gal”) in the “UNIT” menu with an arrow key

The S1Ca is calibrated.

The corresponding continuous displays show the calibrated values.

The total stroke number and total litres are set during calibration to “0”.

The S1Ca is in the STOP status.

**7.5.2 Settings for “auxiliary frequency” function (AUX menu)**

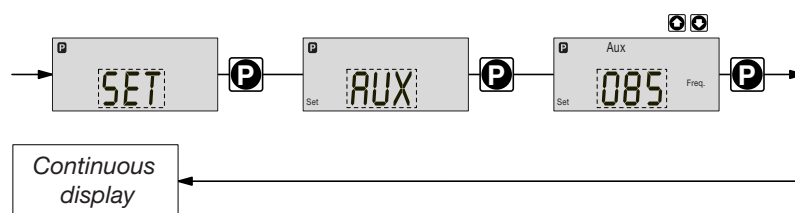

The programmable function “auxiliary frequency” allows switching to a different stroke frequency, which can be set in the AUX menu. It can be activated via the “external control” terminal. When the auxiliary frequency is activated, “aux” appears in the LCD display. This auxiliary frequency overrides the current stroke frequency set for the selected operating mode.

### 7.5.3 Settings for the “flow” function (FLOW menu)

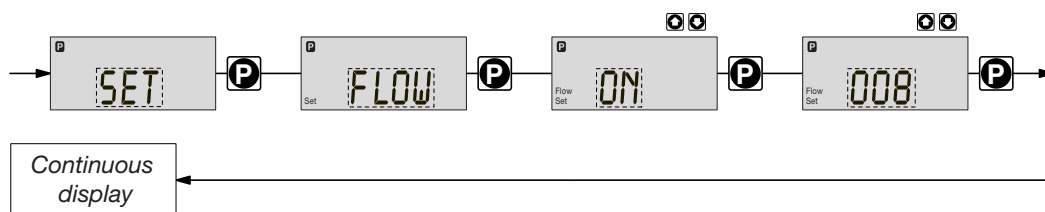

The flow menu only appears when a dosing monitor is connected to the “dosing monitor” terminal. This dosing monitor registers each discharge stroke of the S1Ca at the discharge connector and transmits it back to the S1Ca. If this response transmission is serially omitted for a period set in the FLOW menu (due to failure or below-minimum dosing) the S1Ca stops.

### 7.6 Setting code (CODE menu)

The code menu is used to select whether you want to prevent access to parts of the settings options.

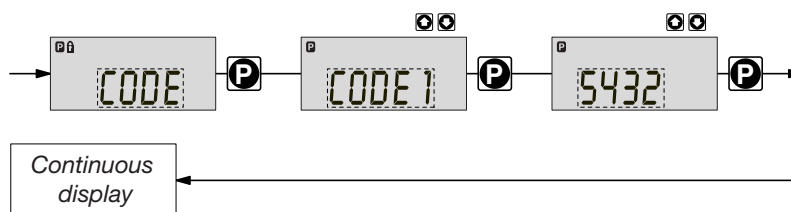

In the first menu option you can choose CODE 1 or CODE 2 (both use the same number).

- Select CODE 1 to prevent access to the settings mode (① in the overview “operating/ settings diagram”, fold-out page). In the next menu option, enter the number you wish to use as the code.
- Select CODE 2 to prevent access to the settings options for directly alterable values in the continuous displays (② in the overview “operating/settings diagram”, fold-out page). In the next menu option, enter the number you wish to use as the code.
- Select NONE to remove a pre-set security lock.

### 7.7 Cancel total stroke number or total litres (CLEAR window)

In the CLEAR window you can delete the stored total stroke number and simultaneously the total litres (= set to “0”). You may then press the P key briefly to exit this window.

The values displayed are counted incrementally from the point of commissioning the pump, or from the last delete action.

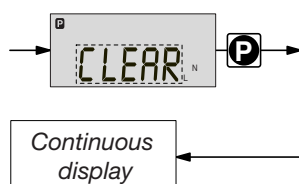

## 8 Operating

This section describes all operating options available to you when the S1Ca is in continuous display mode (no P key symbol in the LCD display).

### **IMPORTANT**

- Open out the fold-out page following the title page fully! There you will find the overviews “control elements and key functions” and “operating/settings diagram”.
- Look at the overview “continuous displays”. This page shows you which displays are available in which operating mode, and which values are directly alterable in the corresponding continuous displays.

### 8.1 Manual operation

*Set stroke length* Stroke length is continually adjustable within a range of 0-100 %. The recommended stroke length range, which will practically guarantee technical reproducibility, is 30-100 % (SEK type: 50-100 %).

### **IMPORTANT**

At low stroking rates (less than 1/3 maximum stroking rate) the controller switches to stop/go mode. This ensures adequate cooling of the motor at low stroking rates.

The following operating options are available via the different keys (see also figure on the next page):

<i>Stop/Start S1Ca</i>	To stop S1Ca: press STOP/START key. To start S1Ca: press STOP/START key.
<i>Start batch</i>	Press the P key briefly in “batch” operating mode.
<i>Load factory settings</i>	Press the P key for 15 s to load factory calibration settings! Current settings will be deleted.
<i>Change to settings mode</i>	When you press the P key for 2 s in any continuous display the S1Ca will change to settings mode (see section 7). If CODE 1 is set, the code must be entered after pressing the P key.
<i>Check adjustable values</i>	Each time you press the i key you will see a different continuous display. The number of continuous displays depends upon the identity code, the selected operating mode and the connected accessories.
<i>Change directly alterable values</i>	To change a value (see below) directly in the corresponding continuous display, press one of the arrow keys until “set” appears in the LCD display. The delay has been programmed in to prevent inadvertent changing of values.  If CODE 2 has been set, this code must be entered after pressing the arrow key.  Directly alterable values are as follows:
<i>Stroke rate</i>	In “manual”, “contact” and “batch” operating modes: The stroke rate can be altered in the “stroke rate” display.
<i>Feed rate</i>	In “manual” operating mode The feed rate can be altered in the “feed rate” display.
<i>Factor</i>	The factor is the number of strokes activated by an external pulse or a press of the P key (in “batch” mode only).  In “Batch” operating mode: You can alter the factor from the “remaining strokes” display. The S1Ca returns to the original continuous display a few seconds after the factor has been reset.
<i>Display program version</i>	Press the P key for 10 seconds to display the program version. Example: “V1052” + “X1010”. In the case of “LOAD3” release the key immediately!

- Batch size** In "batch" operating mode:  
The batch size can be changed from the "batch size/remaining litres" display.  
The S1Ca returns to the original continuous display a few seconds after the batch size has been reset.
- Priming** The "priming" function is activated by pressing both arrow keys at the same time.
- Cancel error** Error messages are cancelled by pressing the P key briefly.

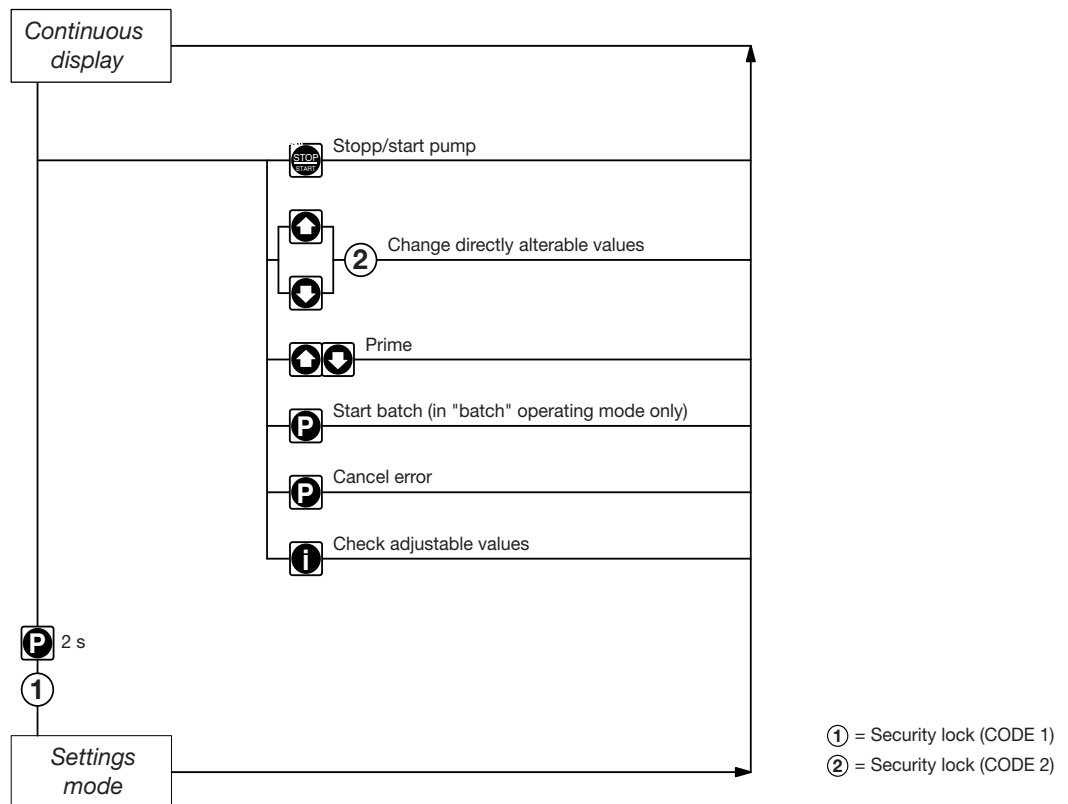

## 8.2 Remote control

Remote control of the S1Ca is possible via a control cable or PROFIBUS® (see Section 5.3 and Chapter 7, „Supplementary instructions for ProMinent® gamma/ L and ProMinent® Sigma versions with PROFIBUS®“ as well as your documentation in the appendix).

## 9 Troubleshooting



### WARNING

- Always take suitable precautions when using hazardous chemicals!
- Ensure the equipment is de-pressurised before working on the pump!

#### Pump primes despite completed stroke action and no venting

- Cause** Crystalline deposits on the ball seat because valves have dried out.
- Remedy**
- ▶ Remove the suction sleeve from the chemical supply container and rinse out the liquid end thoroughly.
  - ▶ If still unsuccessful, dismantle valves and clean.

#### Fluid is seeping from the top plate

- Cause** The liquid end is not sealed against the pump diaphragm.
- Remedy**
- ▶ Tighten screws in the liquid end.
  - ▶ If unsuccessful, replace the diaphragm (see section 4.3).

### **Green LED indicator (operating display) is not lit**

- Cause* Incorrect or no mains voltage.
- Remedy* ► Use the recommended mains voltage as given in the voltage specification on the nameplate.

### **Error Messages**

#### **Red LED display is lit, “Error” and “MINIM” flash in the display**

- Cause* Fluid level in the chemical storage tank has reached “liquid level low, stage 2”.
- Remedy* ► Fill the chemical supply container.

#### **Red LED display is lit, “Error” and “ANALG” flash in the display**

- Cause* S1Ca is in “analogue” operating mode, a fault routine has been programmed in the ANALG menu and the operating current has fallen below 3.8 mA.
- Remedy* ► Remedy low operating current.  
► Switch fault routine “OFF” (see section 7.4.2.).

#### **Red LED display is lit, “Error” and “CNTCT” flash in the display**

- Cause* S1Ca is in “contact” or “batch” operating mode and the extended function “memory” has been set.  
In addition a very large factor has been entered, too many contacts have been input or the P-key has been pressed too often, resulting in an overflow of the stroke memory.
- Remedy* ► Press the P-key, saved data will be deleted.  
► Change S1Ca set up.

#### **Red LED display is lit, “Error” and “FLOW” flash in the display**

- Cause* Dosing monitor not properly connected.
- Remedy* ► Connect dosing monitor properly.  
► Press P-key.
- Cause* Dosing monitor has reported more defective strokes than have been set in the FLOW menu.
- Remedy* ► Press P-key.  
► Investigate the cause and remedy.

#### **Red LED is lit. “Error” appears in the display and “MOTOR” is flashing**

- Cause* The motor is not operating accurately because the backpressure is too high.
- Remedy* ► Reduce backpressure.  
► Press the P key (reset key).
- Cause* The motor is overheating.
- Remedy* ► Check ambient temperature (max. 40 °C).  
► Allow motor to cool down.  
► Press the P key (reset key).
- Cause* Other motor fault.
- Remedy* ► Call ProMinent.  
► Press the P key (reset key).

#### **Red LED is lit. “Error” appears in the display and “TEMPERATURE” is flashing**

- Cause* The temperature in the pump housing is too high because the ambient temperature is too high.
- Remedy* ► Reduce ambient temperature.  
► Allow motor to cool down.  
► Press the P key (reset key).
- Cause* The temperature in the pump housing is too high because the pump is consuming too much power.
- Remedy* ► Check installation, rectify if necessary.  
► Allow motor to cool down.  
► Press the P key (reset key).

**Red LED display is lit, “Error” appears in the display and “FAN” is flashing**

- Cause* Fault related to fan in pump housing.
- Remedy*
- ▶ Check fan and replace if necessary.
  - ▶ Press the P key (reset function).

**Red LED display is lit, “Error” appears in the display and “SYSTEM” is flashing**

- Cause* Controller fault.
- Remedy*
- ▶ Disconnect the pump from the mains and reconnect.  
If the error message continues, send the pump back to ProMinent.

**Red LED lights up, “Error” appears in the display and “Menu” flashes.**

- Cause* Stroke buffer full
- Remedy*
- ▶ Rectify fault
  - ▶ Press P key (Make a note of what effect this has on your process).

**All other Errors**

Please contact your ProMinent branch or representative!

**Fault Signals**

**Yellow LED display is lit**

- Cause* Liquid level in chemical storage tank has reached “liquid level low, stage 1”.
- Remedy*
- ▶ Fill chemical storage tank.

**Yellow LED Display is lit and “calib” flashes**

- Cause* The pump is calibrated and the stroke length deviates by more than ±10 % from the value at the time of calibration.
- Remedy*
- ▶ Reset the stroke length or calibrate the pump again to the desired stroke length.

**10 Decommissioning and disposal**

*Decommissioning*



**WARNING**

- When decommissioning the pump, ensure that all dirt and chemicals are cleaned from the housing and particularly the liquid end.
  - Always take suitable precautions when using hazardous chemicals!
  - Ensure that the equipment is de-pressurised!
- ▶ Disconnect the pump from the mains.
  - ▶ Empty the liquid end by placing the pump on its head and allowing the chemical to drain out.
  - ▶ Rinse the liquid end with a suitable material, thoroughly rinse the liquid end after use with hazardous materials!

If decommissioning is only temporary, maintain the correct storage conditions:

Storage temperature: -10 to +50 °C

Air humidity: < 92 % relative humidity

*Disposal*



**WARNING**

**Spring under tension!**

Take particular care when disassembling the pump as the return spring (Item 5, Chapter 2.2) is under considerable mechanical tension!



**NOTICE**

Observe your locally applicable regulations (particularly with regard to electronic scrap)!

## 11 Spare parts and accessories



### **CAUTION**

The assembly and installation of ProMinent® metering pumps with other-make parts that are not tested and recommended by ProMinent are not permitted and can lead to personal injury and damage to property for which no liability shall be accepted!

### **Spare parts**

You will find the order numbers for the wearing parts in the exploded view drawings in the annex. If you require further parts, please order the "Spare parts list ProMinent® Sigma/ 1".

**Actuator** for automatic stroke adjustment, setting time approx. 1 sec for 1% stroke length, feedback potentiometer 1k Ohm enclosure rating IP 54.

**Control unit** comprising actuator and incorporating servo controller for stroke length adjustment via standard signal. Standard signal input 0/4-20 mA, corresponds to stroke length 0 – 100 %. Manual to automatic mode switch, switch for stroke length adjustment in manual mode, mechanical position display of 0/4-20 mA actual stroke length value output for remote display.

### **Variable speed motors with integrated speed changer (Identcode characteristic V)**

Power supply 1 ph 230 V, 50/60 Hz, 0.09 kW  
Optional external control via 0/4-20 mA

### **Speed controllers in metal casing (Identcode characteristic Z)**

The speed controller kit comprises a speed changer and a 0.09 kW variable speed motor.

### **Float switches**

2-stage, with 2 m connection cable

### **Alarm relays**

For signalling faults

### **Alarm and clock pulse generator relays**

For cyclic timing of other devices and for signalling faults.

### **Control cables**

Universal control cable 5-core/2.5 and 10 m  
External contact cable 2-core/2.5 and 10 m

### **Foot valves**

With intake filter and non-return ball for connection at end of intake line.

### **Metering valves**

With spring-loaded non-return ball for metering in open or closed systems and for mounting the metering line.

### **Backpressure valves**

For exact metering at low operating pressure or as overflow safety valve.

### **Accumulators**

For pulsation damping in long metering lines.

### **Metering monitors**

For monitoring metering operations. After an adjustable number of non-acknowledged metering strokes, a fault is indicated and the metering pump shut down.

### **Intake assemblies**

With foot valve and float switch for expendable packing drums or metering tanks.

### **Metering tanks**

From 35 to 1000 l capacity with lockable screw cover and necessary accessories.

### **Manual/electric stirrers**

For mixing and preparing metering solutions.

Bestell Nr. order no. no. du	<b>Motor data sheet</b> Motor Datenblatt Fiche technique pour moteur				Hersteller producer producteur
<b>1018455</b> <b>1018432</b> <b>1018433</b>					<b>Bonfiglioli</b>
<b>Motor- Typ</b> motor type type du moteur	<b>M2V A56B4</b>		<b>Leistungsfaktor</b> power factor facteur de puissance	<b>0,62/0,66</b>	
<b>Maschinenart</b> type of machine désignation	<b>3-Ph. Motor</b>		<b>Wirkungsgrad</b> efficiency rendement	<b>55,5</b>	%
<b>Schutzart</b> degree of protection degré de protection	<b>IP55</b>		<b>Bemessungsfrequenz</b> rated frequency fréquence nominale	<b>50/60</b>	Hz
<b>Bauform</b> mounting forme de construction	<b>IMV1</b>		<b>Bemessungsdrehzahl</b> rated speed vitesse nominale	<b>1370/1630</b>	U/min rpm t/mn
<b>Bemessungsleistung</b> rated output puissance nominale	<b>0,09 kW</b>	kW	<b>Wärmeklasse</b> temperature class class thermique	<b>F</b>	
<b>Bemessungsspannung</b> rated voltage tension nominale	$\lambda / \Delta$ <b>400/230</b>	V	<b>Anzugsstrom</b> starting current courant de démarrage	<b>2,6</b>	fach fold fois
<b>Bemessungsstrom</b> rated current courant nominal	<b>0,39/0,70 (50 Hz)</b> <b>0,38/0,68 (60 Hz)</b>	A	<b>Anzugsmoment</b> starting torque couple de démarrage	<b>1,8</b>	fach fold fois
<b>Geprüft nach</b> tested in acc. with contrôlé selon	<b>ICE 34-1</b>		<b>Kippmoment</b> pull-out torque couple de décrochage	<b>1,9</b>	fach fold fois
<b>PTB Nr.</b>	<b>ohne EX-Schutz</b>		<b>Umgebungstemperatur</b> ambient temperature température ambiante	<b>max. 40</b>	°C
<b>Anmerkung</b> comments observation These gear motors are available with the above transmissions.	<b>400/230 V</b> <b>380-420/220-240 V (50Hz)</b> <b>400-480/250-280 V (60Hz)</b>		Nr. 1018455 Nr. 1018432 Nr. 1018433	<b>07:1</b> <b>10:1</b> <b>20:1</b>	
<b>ProMinent</b>  Pumpentyp: <b>S1Ba</b> _____ <b>S</b> _____ <b>S1Ca</b> _____ <b>U</b> _____	<b>Nr./no.</b> <b>MD-1018455</b>  <b>Datum/Date</b> 17.06.2002				

Motor datasheets are available for further information.  
Special motors and special motor flanges are possible on request.

## EC Declaration of Conformity

We,

**ProMinent Dosiertechnik GmbH**  
**Im Schuhmachergewann 5 - 11**  
**D - 69123 Heidelberg**

hereby declare that, on the basis of its functional concept and design and in the version brought into circulation by us, the product specified in the following complies with the relevant, fundamental safety and health stipulations laid down by EC regulations.

Any modification to the product not approved by us will invalidate this declaration.

Product description : *Metering pump, series Sigma*

Product type : *S1Ba.../ S1Ca...*

Serial number : *see type identification plate on device*

Relevant EC regulations :  
*EC - machine regulation (98/37/EC)*  
*EC - low voltage regulation (73/23/EEC)*  
*EC - EMC - regulation (89/336/EEC*  
*subsequently 92/31/EEC)*

Harmonised standards used,  
in particular :  
*DIN EN 292-1, DIN EN 292-2, DIN EN 294, DIN EN 809,*  
*DIN EN 12162*  
*DIN EN 60335-1, DIN EN 60335-2-41, DIN EN 50106*  
*DIN EN 61010, 60204-1, DIN EN 60034-1/5/7/18, DIN EN 60525*  
*DIN EN 50081-1/2, DIN EN 50082-1, 61000-6-2, DIN EN 55014-1/2*  
*DIN EN IEC 61000-3-2, 61000-3-3, DIN EN 61800-3*

National standards and other  
technical specifications used,  
in particular :  
*VDE 0530 T1/T5/T7/T18*  
*IEC 60034-1/5/7/18, IEC 38*  
*DIN EN IEC 60068-2-30*

Date/manufacturer's signature : *22.07.2002*

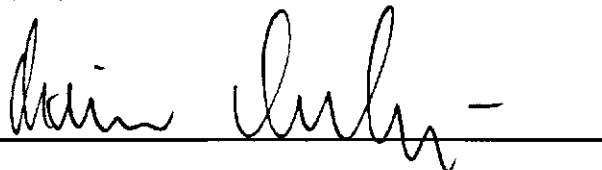

The undersigned : *Dr. Rainer V. Dulger, Executive Vice President R&D and Production*

Delivery unit Sigma/ 1 120 PVT for identity code types: 04084, 04120, 07042

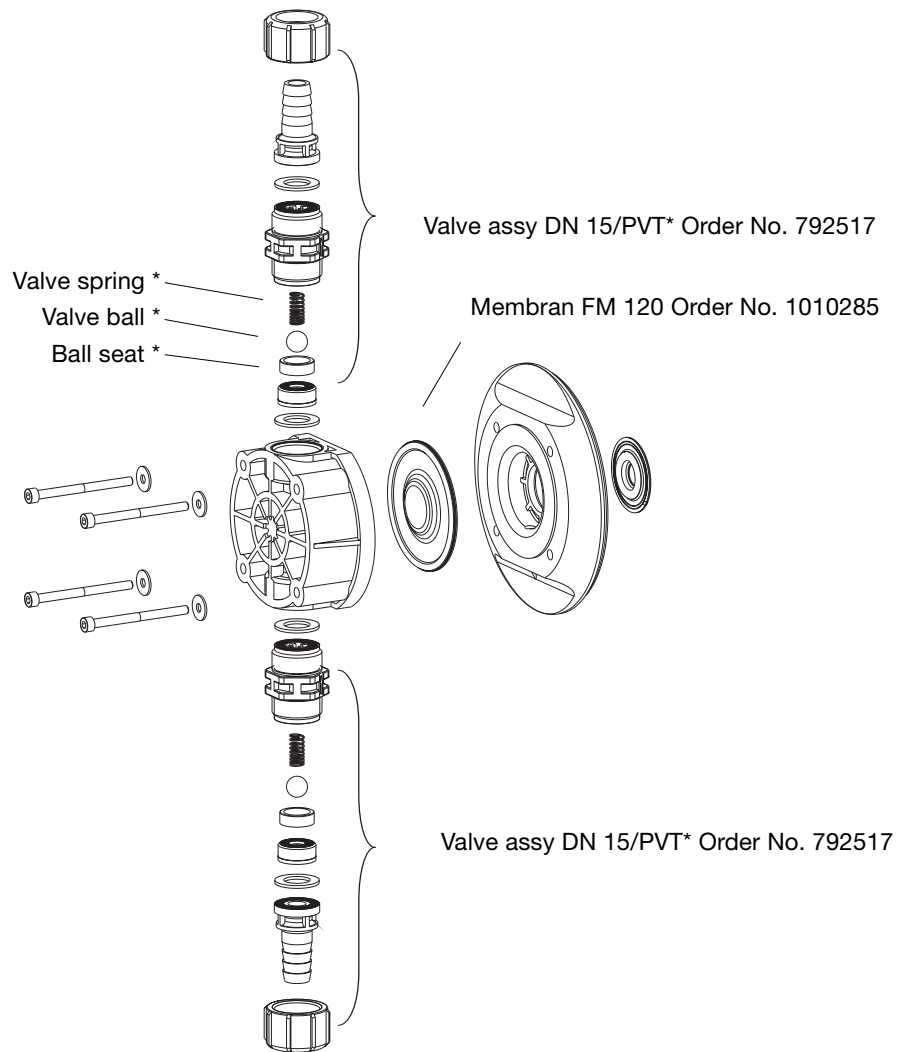

Spare parts kit FM 120 PVT Order No. 1010543

\* The listed items are constituent parts of the spare part kit.  
Subject to technical modifications.

Fig. 25  
61\_05-104\_00\_99-03\_2

## Exploded diagrams of liquid ends

Delivery unit Sigma/ 1 050 PVT ÜV-A for identity code types: 12035, 10050, 12017

Delivery unit Sigma/ 1 065 PVT ÜV-A for identity code types: 07065, 10044, 10022

Delivery unit Sigma/ 1 120 PVT ÜV-A for identity code types: 04120, 04084, 07042

Overflow valve assy 12 bar PVA Order No. 1018572

Overflow valve assy 10 bar PVA Order No. 1018947

Overflow valve assy 7 bar PVA Order No. 740811

Overflow valve assy 4 bar PVA Order No. 740812

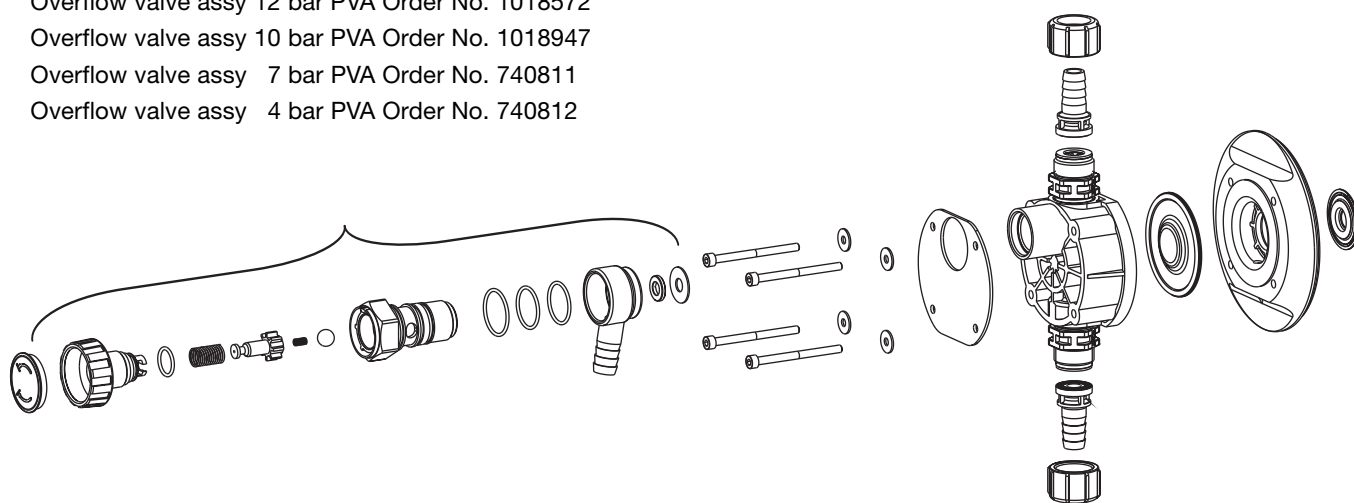

For other spare parts see delivery unit without overflow valve (see p. 56 and p. 57).

Subject to technical modifications.

Fig. 26  
61\_05-104\_01\_00-03\_2

Delivery unit Sigma/ 1 050 SST for identity code types: 12035, 12017, 10050  
 Delivery unit Sigma/ 1 065 SST for identity code types: 07065, 10044, 10022

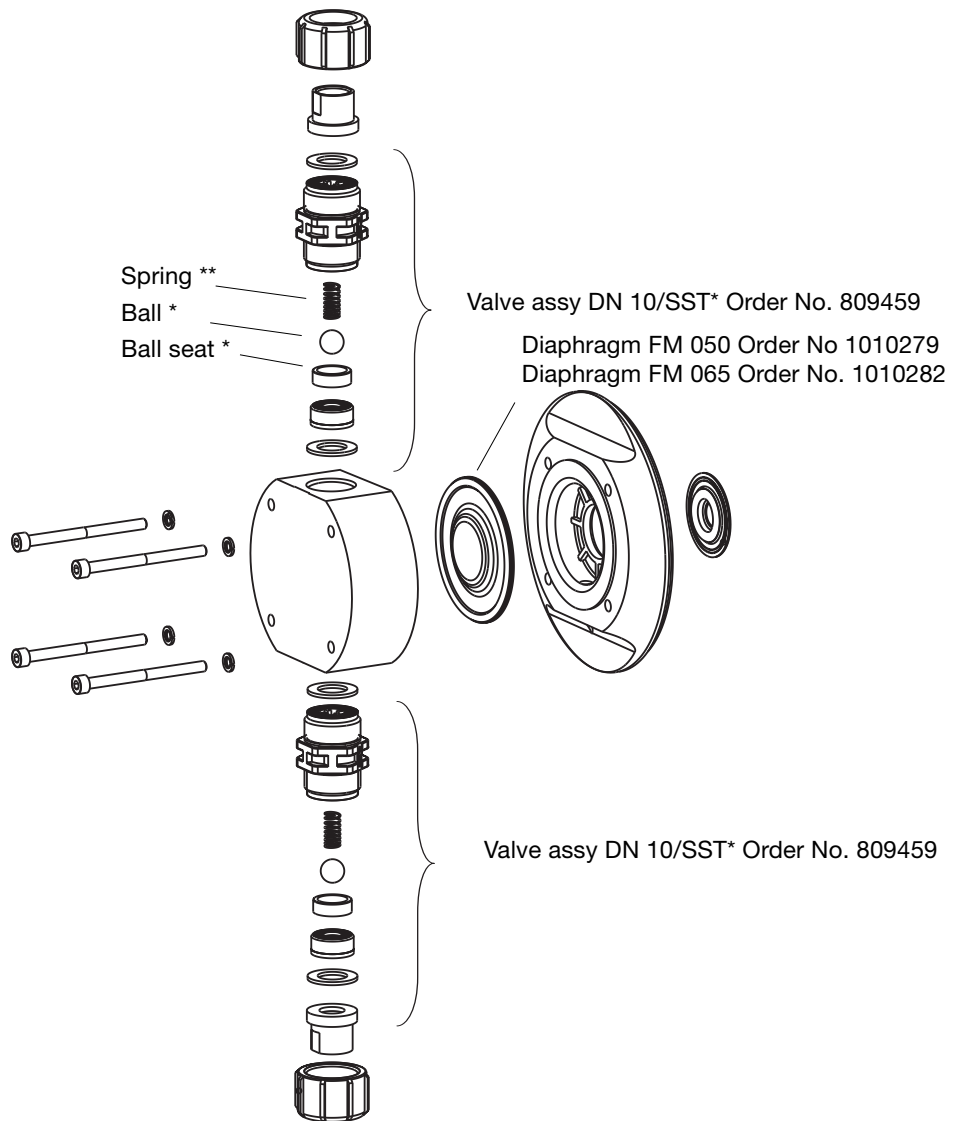

Spare parts kit FM 50 SST without valve	Order No. 1010554
Spare parts kit FM 50 SST without valve	Order No. 1010555
Spare parts kit FM 65 SST without valve	Order No. 1010556
Spare parts kit FM 65 SST without valve	Order No. 1010557

\* The listed items are constituent parts of the spare part kit.  
 \*\* Special accessories (not included in spare part kit).  
 Subject to technical modifications.

Fig. 27  
 61\_05-104\_01\_01-03\_2\_norm

## Exploded diagrams of liquid ends

Delivery unit Sigma/ 1 120 SST for identity code types: 04084, 04120, 07042

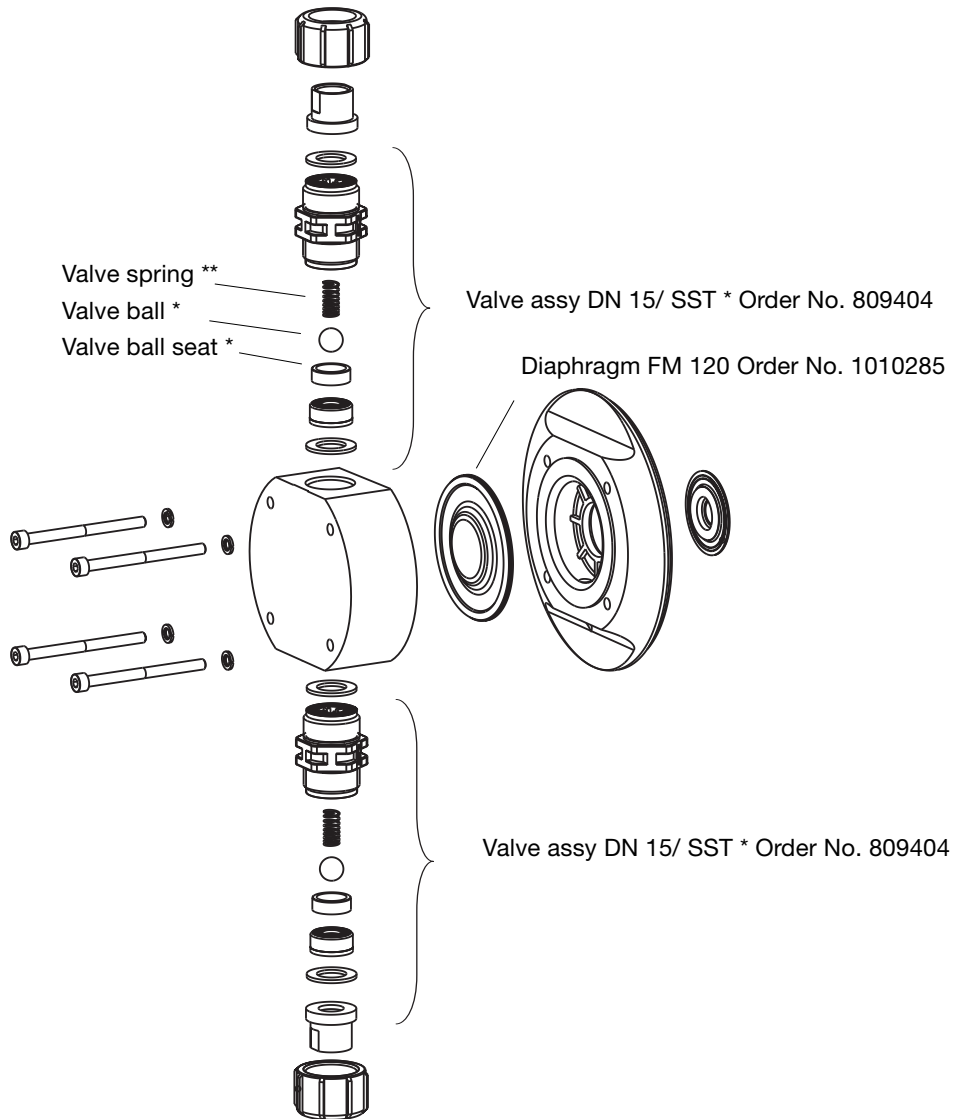

Spare parts kit FM 120 SST without valve      Order No. 1010558  
Spare parts kit FM 120 SST with valve      Order No. 1010559

\* The listed items are constituent parts of the spare part kit.  
Subject to technical modifications.

Fig. 28  
61\_05-104\_01\_01-03\_2\_norm

Delivery unit Sigma/ 1 050 SST ÜV-A for identity code types: 12035, 12017, 10050

Delivery unit Sigma/ 1 065 SST ÜV-A for identity code types: 07042, 07065, 10044, 10022

Delivery unit Sigma/ 1 120 SST ÜV-A for identity code types: 04120, 04084, 07042

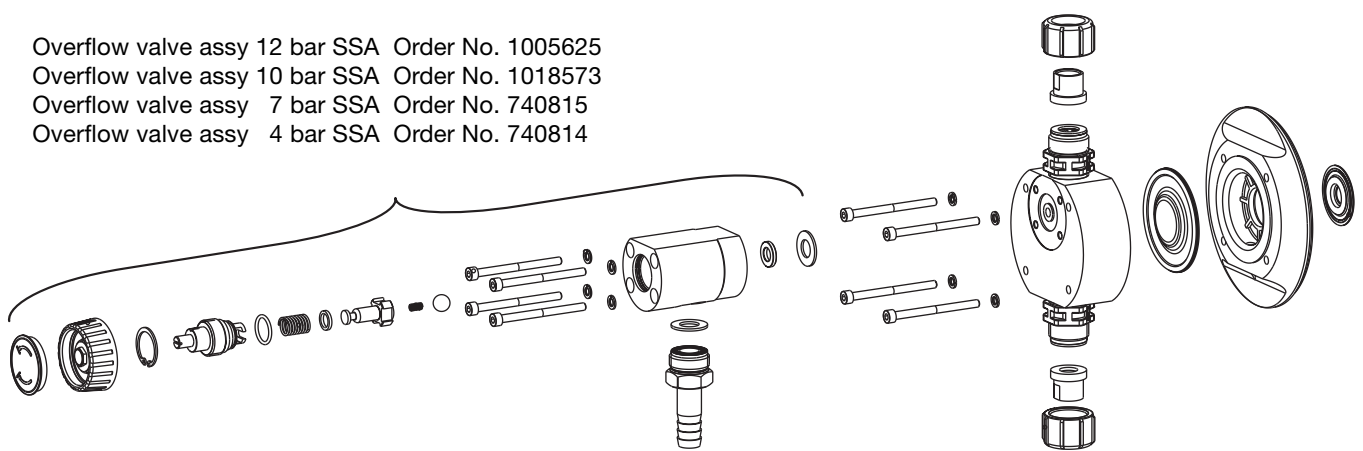

For other spare parts see delivery unit without overflow valve (see p. 59 and p. 60).

Subject to technical modifications.

Fig. 29  
 61\_05-104\_01\_01-03\_02

Retrofit kit double diaphragm S1Ba/S1Ca

- S1Ba Retrofit kit double diaphragm FM 050 Order No. 1009846
- S1Ba Retrofit kit double diaphragm FM 065 Order No. 1009848
- S1Ba Retrofit kit double diaphragm FM 120 Order No. 1009850
- S1Ca Retrofit kit double diaphragm FM 050 Order No. 1009847
- S1Ca Retrofit kit double diaphragm FM 065 Order No. 1009849
- S1Ca Retrofit kit double diaphragm FM 120 Order No. 1009851

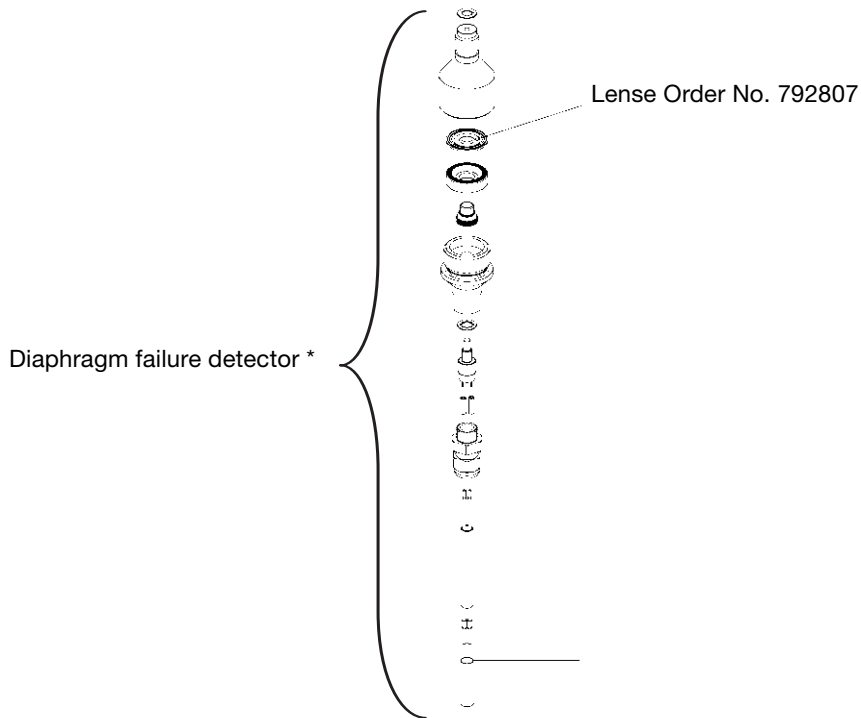
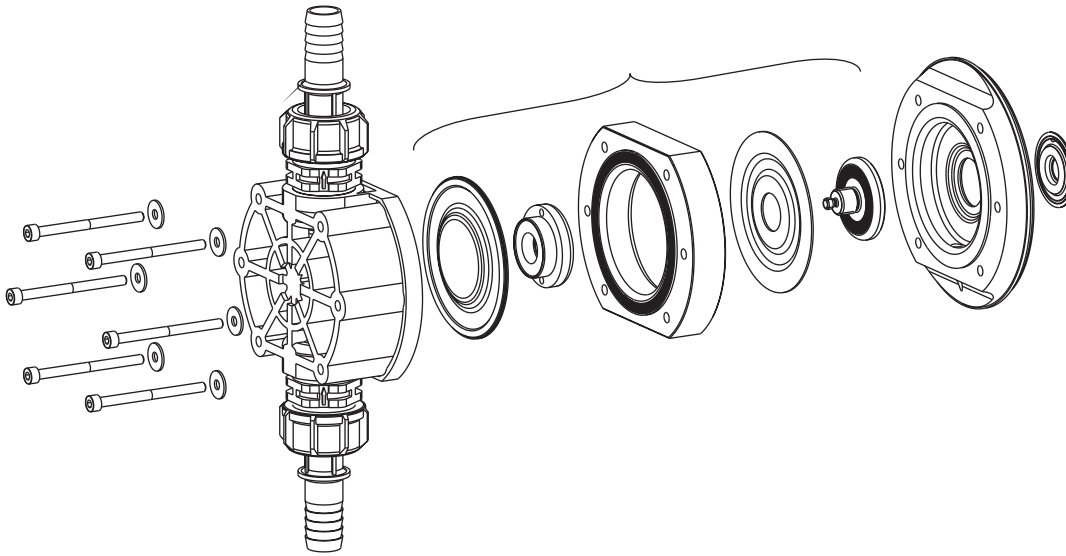

\* The listed items are constituent parts of the spare part kit.  
Subject to technical modifications.

Fig. 30  
61\_05-104\_00\_98-03\_2

Stroke actuator wiring diagram

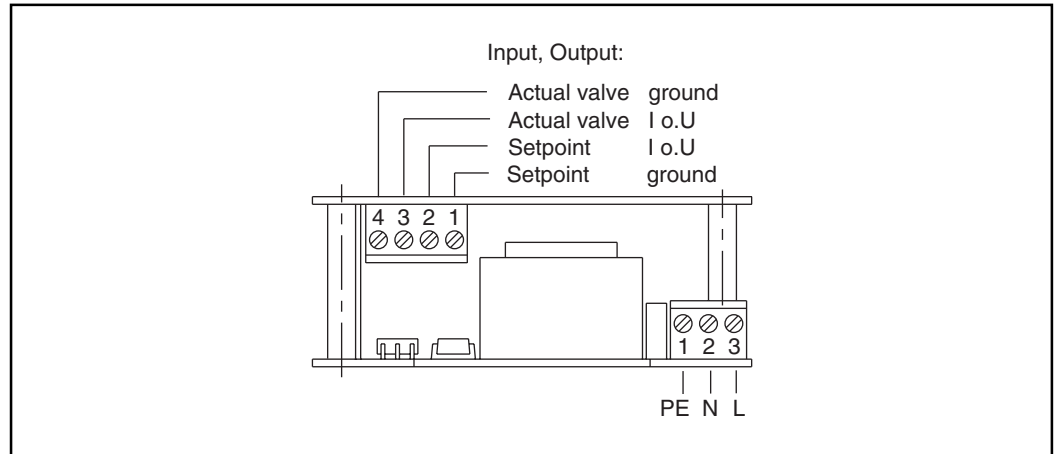

Stroke adjuster wiring diagram

