

## 8000A Series Compact Magnetic Flowtubes Wafer Body, Ceramic- or pfa-Lined 1.6 to 150 mm (1/16 to 6 in) Line Sizes



These compact, ceramic- or pfa-lined, wafer body flowtubes, together with an IMT25 Magnetic Flow Transmitter, combine to form an easy-to-use, versatile, dc pulsed Magnetic Flowmeter. The flowmeter is compatible with most conductive liquids. These flowtubes are offered in 1.6 to 150 mm (1/16 to 6 in) sizes. As symbolized by the CE Logo marking on the product, these flowtubes conform to the applicable European Union directives.

### FEATURES

- Compact design.
- Ceramic lining excellent selection for high temperature and highly abrasive processes.
- Retained pfa lining can withstand pressure and temperature extremes. Excellent in corrosive environments. Excellent blistering resistance.
- Proven electrode seal design.
- Wide range of electrode materials. Conical electrode types also offered in 316 ss or Hastelloy® C for pfa-lined flowtubes.
- Large electrode surface area means less sensitivity to entrained air.
- Tapered inlets reduce profile effects.
- Wafer body mounts between ANSI or metric flanges.
- NEMA® 4X construction for environmental and corrosion resistant protection.
- Used with remote- or integrally-mounted transmitters.
- Total quality management including ISO 9001 Certification.
- Standard 2-year warranty.

## **SUPERIOR REPUTATION FOR DEPENDABILITY AND QUALITY**

Foxboro introduced magnetic flow measurement systems to the process industries in 1954 and has demonstrated the broadest and most time-proven application expertise with tens of thousands of successful installations.

## **AN INTELLIGENT PATH TO MAGNETIC FLOW SYSTEMS**

The merging of the latest technology in flowtube design and a microprocessor-based transmitter provides the process industries a significant advancement in liquid flow measurement. The flowmeter can provide 4 to 20 mA dc, pulse, and digital outputs, based on FoxCom protocol. FoxCom includes the I/A Series® system, the Foxboro Model HHT Hand-Held Terminal, and the Foxboro Model PC10 Configurator.

## **DESIGNED FOR WIDE VARIETY OF PROCESSES**

These compact, lightweight, wafer body (flangeless), ceramic- or pfa-lined flowtubes, with a large selection of electrode materials, provide excellent corrosion and abrasion resistance. These features allow for higher flow velocities (therefore greater rangeability) and also make it suitable for all types of processes including those involving high pressure, high temperature, or vacuum service.

## **PULSED dc FLOWTUBE USED WITH REMOTE- OR INTEGRALLY-MOUNTED TRANSMITTER**

The 8000A Series Magnetic Flowtubes are calibrated for use with pulsed dc coil excitation. Foxboro offers the I/A Series Intelligent Magnetic Flow Transmitter (Model IMT25) for use with these flowtubes.

The IMT25 Transmitter is offered for installation in a remote location (pipe or surface mounting), or integrally mounted to the flowtube, 15 to 150 mm (1/2 to 6 in) sizes only.

These flowtubes are also backward-compatible with Foxboro 8000, IMT10, and IMT20 Series Pulsed dc Transmitters.

## **FLOWTUBE CALIBRATION**

All flowtubes are wet calibrated to verify their specified accuracy with traceability to the U.S. National Institute of Science and Technology (NIST).

## **LOW POWER CONSUMPTION**

All flowmeter configurations are designed to consume less than 24 W of power at reference voltage and frequency.

## **NUMEROUS CONFIGURATIONS AVAILABLE**

Flowtube sizes range from 1.6 to 150 mm (1/16 to 6 in) for ceramic-lined flowtubes, and 15 to 150 mm (1/2 to 6 in) for pfa-lined flowtubes. Depending on the flowtube size selected, ceramic-lined flowtubes are offered with tantalum or platinum electrodes, while pfa-lined flowtubes are available with tantalum-tungsten, 316 ss, Hastelloy C, platinum-iridium, or titanium electrodes. All flowtubes can be mounted between Class 150 or 300 flanges, or Metric PN 10 to PN 40 flanges.

## **CONICAL ELECTRODES OFFERED**

Conical electrodes are offered in both Hastelloy C and 316 ss with pfa-lined flowtubes sized 25 mm (1 in) or larger. These are excellent selections for applications where processes can coat conventional flush-with-lining electrodes. With conicals, the electrode point extends into the process where the process fluid tends to sweep the electrodes clean.

## **WEATHERPROOF AND CORROSION RESISTANT CONSTRUCTION**

These flowtubes are designed to operate in harsh outdoor or in-plant environments. The flowtube enclosure is weatherproof as defined by IEC IP66 and provides the watertight and corrosion-resistant protection of NEMA Type 4X. An accidental submergence flowtube housing is also offered for use with remote-mounted transmitters.

## **TQM — TOTAL QUALITY MANAGEMENT**

The TQM program is Foxboro's commitment to total product quality and customer satisfaction.

Foxboro has met all of the requirements of the International Quality Standard 9001 and was officially certified in April of 1991 for the "Design and Manufacturing of Process Control and Automation Equipment". The certification applies to Foxboro's entire US-based operations including manufacturing, design/development, production, installation, and service. The certification has remained valid since the initial award, as Foxboro has successfully passed scheduled periodic audits performed by the certifying agency.

## MODEL CODE

<u>Description</u>	<u>Model</u>
Compact Magnetic Flowtube, 1.6 mm (1/16 in) Line Size – Ceramic Lining Only (c)	801SA
Compact Magnetic Flowtube, 3 mm (1/8 in) Line Size – Ceramic Lining Only (c)	801EA
Compact Magnetic Flowtube, 6 mm (1/4 in) Line Size – Ceramic Lining Only (c)	801QA
Compact Magnetic Flowtube, 15 mm (1/2 in) Line Size – Ceramic and pfa Lining	800HA
Compact Magnetic Flowtube, 25 mm (1 in) Line Size – Ceramic and pfa Lining	8001A
Compact Magnetic Flowtube, 40 mm (1 1/2 in) Line Size – Ceramic and pfa Lining	801HA
Compact Magnetic Flowtube, 50 mm (2 in) Line Size – Ceramic and pfa Lining	8002A
Compact Magnetic Flowtube, 80 mm (3 in) Line Size – Ceramic and pfa Lining	8003A
Compact Magnetic Flowtube, 100 mm (4 in) Line Size – Ceramic and pfa Lining	8004A
Compact Magnetic Flowtube, 150 mm (6 in) Line Size – Ceramic and pfa Lining	8006A
<b><u>Tube Construction/End Connection</u></b>	
Wafer Body, Mounts between ANSI Class 150 or 300, or DIN PN 10 to PN 40 Flanges	–W
<b><u>Lining Material</u></b>	
Ceramic – All Flowtube Sizes	C
Perfluoroalkoxy (pfa) – 15 to 150 mm (1/2 to 6 in) Sizes Only	P
<b><u>Transmitter Mounting</u></b>	
Remote Mounting to a Pipe or Surface	R
Flowtube Mounting to IMT20 Transmitter, 800HA to 8006A Only	T
Flowtube Mounting to IMT25 Transmitter 800HA to 8006A Only	I
<b><u>Electrodes</u></b>	
Tantalum, 1.6 to 6 mm (1/16 to 1/4 in) Ceramic-Lined Flowtube, or Tantalum-Tungsten, 15 to 150 mm (1/2 to 6 in) pfa-Lined Flowtubes	–B
Conical 316 ss, 25 to 150 mm (1 to 6 in) pfa-Lined Flowtubes Only	–C
Hastelloy C, 15 to 150 mm (1/2 to 6 in) pfa-Lined Flowtubes Only	–H
Conical Hastelloy C, 25 to 150 mm (1 to 6 in) pfa-Lined Flowtubes Only	–K
Platinum, 1.6 to 150 mm (1/16 to 6 in) Ceramic-Lined Flowtubes, or Platinum-Iridium, 15 to 150 mm (1/2 to 6 in) pfa-Lined Flowtubes	–P
316 ss, 15 to 150 mm (1/2 to 6 in) pfa-Lined Flowtubes	–S
Titanium, 15 to 150 mm (1/2 to 6 in) pfa-Lined Flowtubes Only	–T
<b><u>Coil Drive/Supply</u></b>	
Pulsed dc (From Intelligent I/A Series Magnetic Flow Transmitters)	J
<b><u>Housing Construction</u></b>	
NEMA 4X Housing, Used with Remote- or Integrally-Mounted Transmitter	G
Accidental Submergence, Used with Remote-Mounted Transmitter Only	H
<b><u>Electrical Safety(a)</u></b>	
CSA, Ordinary Locations	CGZ
CSA, Class I, Division 2	CNZ
European, Nonincendive, Zone 2	KNZ
FM, Ordinary Locations	FGZ
FM, n	FNA
CENELEC, e, ia (Environment and Pipeline, Zone 1)	ESB
No Certification	ZZZ
<b><u>Optional Selection(s)</u></b>	
Mounting Hardware for ANSI Class 150 Flanges	–A
Mounting Hardware for ANSI Class 300 Flanges	–B
Mounting Hardware Metric PN 10 Flanges	–C
Mounting Hardware Metric PN 16 Flanges	–D
Cable Glands for Nonconduit Applications (b) Select with Transmitter Mounting Code R only	–G
Examples: 8001A–WCR–PJHCGZ–AG; 8002A–WPI–SJGFNA–A	

(a) These Flowtubes have been designed to meet the specified electrical safety descriptions. For status of testing laboratory approvals or certifications, contact Foxboro. Also see “Electrical Safety Specifications” section.

(b) The cable glands (–G option) provide a sealed cable entry for field wiring to the flowtube junction box, and are generally specified in non-conduit applications. For flowtube with integrally-mounted transmitters (–T or –I Housing), cable glands may be specified with the transmitter options (not for CNZ or FNA Electrical Safety Codes).

(c) These flowtubes are designed and calibrated for installation between 15 mm (1/2 in) flanges.

## OPERATING CONDITIONS

### Operating Conditions – Ceramic-Lined Flowtube

Influence	Reference Operating Conditions	Operating Condition Limits	
		with Remote-Mounted Transmitter	with Integrally-Mounted IMT25
Ambient Temperature	25 ±2°C (77 ±3.6°F)	–40 and +70°C (–40 and +158°F)	–30 and +70°C(c) (–22 and +158°F)
Process Temperature	25 ±2°C (77 ±3.6°F)	–40 and +204°C (–40 and +400°F)	–40 and +121°C (–40 and +250°F)
Process Pressure 1.6 to 50 mm (1/16 to 2 in) See Note (a),(b)	0.517 MPa (75 psi)	Full Vacuum and: 5.1 MPa at 38°C (740 psi at 100°F) and 4.4 MPa at 204°C (635 psi at 400°F)	Full Vacuum and: 5.1 MPa at 38°C (740 psi at 100°F) and 4.7 MPa at 121°C (665 psi at 250°F)
Process Pressure 80 to 150 mm (3 to 6 in) See Note (a),(b)	0.517 MPa (75 psi)	Full Vacuum and: 4.6 MPa at 38°C (675 psi at 100°F) and 4.0 MPa at 204°C (580 psi at 400°F)	Full Vacuum and: 4.6 MPa at 38°C (675 psi at 100°F) and 4.3 MPa at 121°C (625 psi at 250°F)

(a) The pressure-temperature values listed are for the flowtube itself. The flange type, rating, and material used during installation may have a lower pressure-temperature limit than the flowtube. **DO NOT** exceed the applicable flange pressure-temperature limit.

(b) Maximum allowable step change in temperature difference between process and ceramic lining is an increase of 125°C (225°F) and a decrease in 75°C (135°F).

(c) With IMT25 Integral Display option B, lower limit is –20°C (–4°F). See PSS 1-6F5 A for transmitter Normal Operating Conditions.

### Operating Conditions – pfa-Lined Flowtube

Influence	Reference Operating Conditions	Operating Condition Limits	
		with Remote-Mounted Transmitter	with Integrally-Mounted IMT25
Ambient Temperature	25 ±2°C (77 ±3.6°F)	–40 and 70°C (–40 and +158°F)	–30 and +70°C(b) (–22 and +158°F)
Process Temperature	25 ±2°C (77 ±3.6°F)	–40 and +180°C (–40 and +356°F)	–40 and +121°C (–40 and +250°F)
Process Pressure See Note (a)	0.517 MPa (75 psi)	Full Vacuum and: 5.1 MPa at 38°C (740 psi at 100°F) and 4.4 MPa at 180°C (645 psi at 356°F)	Full Vacuum and: 5.1 MPa at 38°C (740 psi at 100°F) and 4.7 MPa at 121°C (665 psi at 250°F)

(a) The pressure-temperature values listed are for the flowtube itself. The flange type, rating, and material used during installation may have a lower pressure-temperature limit than the flowtube. **DO NOT** exceed the applicable flange pressure-temperature limit.

(b) With IMT25 Integral Display option B, lower limit is –20°C (–4°F). See PSS 1-6F5 A for transmitter Normal Operating Conditions.

### PERFORMANCE SPECIFICATIONS

(Combined Flowtube and Transmitter System under Reference Operating Conditions)

Flowmeter System	Refer to
8000A Flowtube with 8000 Series Transmitter	Contact Foxboro
8000A Flowtube with IMT10 Series Transmitter	Contact Foxboro
8000A Flowtube with IMT20 Series Transmitter	PSS 1-6F3 B
8000A Flowtube with IMT25 Series Transmitter	PSS 1-6F5 A

### FUNCTIONAL SPECIFICATIONS

#### Minimum and Maximum Upper Range Values

See Table 1. In this table, the minimum upper range value (URV) is not the lowest flow rate that the flowtube can measure; it is the lowest flow rate which can correspond to the 20 mA signal. For example: for the 1/2 in flowtube, the minimum range is 0 to 1.0 U.S. gpm, and this will generate 4 to 20 mA.

#### Process Pressure and Temperature Limits

Refer to applicable table in "Operating Conditions" section.

#### Lining and Electrode Application Guide

Ceramic provides excellent abrasion resistance and is suitable for high pressure, high temperature, or vacuum service process applications. PFA is an equally preferred lining except it should not be used in severe abrasive processes. It is, however, the recommended lining in processes requiring excellent resistance to thermal shock and liner coating problems. Refer to Table 2. Also, refer to TI 27-71f for an application guide for the use of flowtube linings and electrode materials vs. approximately 150 different process fluids.

Table 1. Minimum and Maximum Upper Range Values

Nominal Line Size		Nominal Tube I.D.		Flow Velocity Minimum and Maximum URV		Flow Rate Minimum and Maximum URV	
mm	in	mm	in	m/s	ft/s	L/min	U.S. gpm
1.6	1/16	1.57	0.062	0.97 and 10	3.19 and 33	0.11 and 1.1	0.03 and 0.3
3	1/8	3.175	0.125	0.56 and 10	1.83 and 33	0.26 and 4.92	0.07 and 1.3
6	1/4	5.33	0.210	0.51 and 10	1.67 and 33	0.68 and 13.6	0.18 and 3.6
15	1/2	12.7	0.50	0.50 and 10	1.64 and 33	3.8 and 76	1 and 20
25	1	23.6	0.93	0.50 and 10	1.64 and 33	13.2 and 265	3.5 and 70
40	1 1/2	37.1	1.46	0.50 and 10	1.64 and 33	34.1 and 644	9.0 and 170
50	2	45.0	1.77	0.50 and 10	1.64 and 33	49 and 946	13 and 250
80	3	70.6	2.78	0.50 and 10	1.64 and 33	117 and 2366	31 and 625
100	4	94.0*	3.70*	0.50 and 10	1.64 and 33	208 and 4164	55 and 1100
150	6	139.7*	5.50*	0.50 and 10	1.64 and 33	462 and 9236	122 and 2440

\*I.D. of 100 and 50 mm (4 and 6 in) pfa-lined tubes are slightly smaller than shown.

Table 2. Flowtube Lining Selection Guide

Flowtube Construction	Process Fluid Characteristic (a)					
	Clean	Mild Corrosion	Severe Corrosion	Mild Abrasion	Severe Abrasion	Mild Corrosion and Abrasion
pfa Lining	A	A	A	B	X	B
Ceramic Lining	A	A	B	A	B (b)	A

- (a) A = Preferred selection. Generally considered the best choice.  
 B = Satisfactory selection. Reasonable life under most conditions.  
 X = Not recommended. Generally considered unacceptable.

(b) This characteristic can be upgraded to A for process fluid velocities less than 0.91 m/s (3 ft/s).

**Accidental Submergence**

The flowtube is prepared with special sealing techniques for operation up to 48 hours under 10 m (33 ft) of water maximum. For use with remote-mounted transmitter only. Select Model Code Housing Construction H.

**Process Fluid Conductivity and Signal Cable Length**

The maximum allowable cable length is a function of the cable type, process fluid conductivity, and whether the cables are in the same or separate conduits. Standard system accuracy will be maintained when the installations are in accordance with Table 3.

Table 3. Process Fluid Conductivity and Cabling

Maximum Cable Length	Minimum Fluid Conductivity	Signal and Coil Drive Cables
300 m (1000 ft)	5 µS/cm	Signal and Coil Drive Cables in separate conduit. Signal Cable to be Foxboro Part No. R0101ZS (feet) or B4017TE (metres).
225 m (750 ft)	5 µS/cm	Signal and Coil drive cables in same conduit. Signal Cable to be Foxboro Part No. R0101ZS (feet) or B4017TE (metres).
150 m (500 ft)	20 µS/cm	Signal cable may be in same conduit as coil drive cable. Signal cable to be good quality twisted shielded pair, preferable no smaller than 1.0 mm <sup>2</sup> (or 18 AWG) for mechanical considerations (Belden 8760 or 9318, Alpha 5610/1801 or 5611/1801, or equivalent).

(a) Values in table are fluid conductivity minimums, and maximum distance between transmitter and flowtube. Refer to TI 27-072 for conductivities of various process liquids.

**ELECTRICAL SAFETY SPECIFICATIONS**

Testing Laboratory, Types of Protection and Area Classification	Application Conditions	Electrical Safety Design Code
CSA general purpose (ordinary) locations.	—	CGZ
CSA Class I, Division 2, Groups A, B, C, and D; Class II, Division 2, Groups F and G; and Class III, Division 2 hazardous locations.	Temperature Class T6.	CNZ
FM general purpose (ordinary) locations.	—	FGZ
FM nonincendive, Class I, Division 2, Groups A, B, C, and D; suitable for Class II, and III, Division 2, Groups F and G hazardous locations.	Temperature Class T6. For use on non-hazardous process only.	FNA
CENELEC Zone 1, Gas Group II C	Temperature Class T3-T6. Electrodes are intrinsically safe when connected to certified intrinsically safe equipment.	ESB
European nonincendive, Zone 2, Gas Group II C.	Temperature Class T2-T6.	KNZ
No certification	—	ZZZ

**NOTE**

The 8000A Series Flowtubes have been designed to meet the electrical safety descriptions listed in the table above. For detailed information, or status of testing laboratory approvals or certifications, contact Invensys Foxboro.

## PHYSICAL SPECIFICATIONS

### Materials

#### FLOWTUBE HOUSING

Ductile iron

#### JUNCTION BOX (w/REMOTE TRANSMITTER)

Cast aluminum

#### FLOWTUBE LINER

Ceramic (99.5% aluminum oxide) or pfa (perfluoroalkoxy)

#### ELECTRODES (CERAMIC-LINED FLOWTUBES)

Platinum. Tantalum for 1/16 to 1/4 in sizes only

#### ELECTRODES (pfa-LINED FLOWTUBES)

Tantalum-Tungsten

316 ss

Conical 316 ss (1 to 6 in sizes only)

Hastelloy C

Conical Hastelloy C (1 to 6 in sizes only)

Platinum-Iridium

Titanium

#### FLANGE GASKETS

Gylon<sup>®</sup> (ptfe/barium sulfate) for ceramic-lined flowtubes. User provides own gasket on pfa-lined flowtubes.

#### JUNCTION GASKET

Box/Cover Silicone Sponge Rubber

Box/Housing Silicone Rubber/Cork

#### LOCATOR CAM

Nylon

### Flowtube Construction

#### CERAMIC-LINED TUBES

One-piece all ceramic construction

#### pfa-LINED TUBES

Cast 304 ss or 305 ss tube with reinforced and retained pfa liner

### Flowtube End Connections and Construction

Wafer body. Mounts between DIN PN 10 to PN 40 flanges; or ANSI Class 150 or 300 R.F. flanges.

Flange bolting kits are available from Foxboro for the ANSI Class 150 and 300 flanges, and DIN PN 10 and PN 16 flanges.

### Flowtube-Mounted Transmitter (1/2 to 6 in only)

The transmitter is bolted to the terminal housing of the flowtube. See "Dimensions—Nominal" section.

### Mounting Position

The flowtube can be mounted at any orientation without degrading performance. The only requirements are that the flowtube be completely full with the process liquid during measurement, and that the electrodes be in horizontal plane. Installation in a vertical pipeline with flow going upward is ideal. Recommended straight run of pipe is five pipe diameters upstream and three pipe diameters downstream.

### Electrical Connections

Refer to "DIMENSIONS—NOMINAL" section.

### Grounding Rings

Needed if mating piping is nonmetallic or lined. When required, grounding rings must be at both ends of the flowtube. Grounding rings (i.e., orifice plates) are available from Foxboro, if needed.

### Enclosure

The enclosure is finished with a high-build epoxy paint, and is designed to meet the requirements of IEC IP66 and to meet the watertight and corrosion-resistant protection of NEMA Type 4X.

### Approximate Mass

Flowtube Size		With Ceramic Lining	With pfa Lining
mm	in		
1.6	1/16	2.3 kg (5 lb)	Not Available
3	1/8	2.3 kg (5 lb)	Not Available
6	1/4	2.3 kg (5 lb)	Not Available
15	1/2	2.3 kg (5 lb)	1.7 kg (3.7 lb)
25	1	3.0 kg (6.6 lb)	2.4 kg (5.4 lb)
40	1 1/2	3.5 kg (7.7 lb)	2.9 kg (6.5 lb)
50	2	4.5 kg (9.9 lb)	3.5 kg (7.7 lb)
80	3	7.0 kg (15.4 lb)	7.3 kg (16.1 lb)
100	4	10.0 kg (22 lb)	11.8 kg (26.4 lb)
150	6	17.7 kg (39 lb)	22.7 kg (50 lb)

NOTE: See applicable transmitter PSS for transmitter mass and add to flowtube mass (1/2 in and above only) to get assembled mass of flowtube and transmitter.

### OPTIONAL FEATURES

#### Foxboro Signal Cable

For Remote-Mounted Transmitter applications only. Two-core (two-conductor), multiscreened (multi-shielded) cable with two driven screens (shields). Maximum length is 300 m (1000 ft). This cable (Part Number R0101ZS for length in feet, or B4017TE for length in metres) is identified here for reference only. This cable is generally specified with transmitter order.

#### Cable Glands

For Remote-Mounted Transmitter and nonconduit applications only. Used to provide rain tight, strain relieved entrance for 6.8 to 12.2 mm (0.27 to 0.48 in) diameter cable. External 1/2 NPT threads into internal 1/2 NPT thread on transmitter or flowtube cable entry surface. Body and seal nut are nylon, and compression gland is neoprene. Selectable using Model Code option -G.

#### Mounting Hardware

Flange bolt kits available for installing flowtubes between ANSI Class 150, ANSI Class 300, PN 10 or PN 16 flanges. Select Model Code Optional Suffix -A, -B, -C, or -D, respectively.

### ORDERING INSTRUCTIONS

1. Model Number
2. Flow Rate and Engineering Units Required. Value specified must be within minimum and maximum upper range values listed in Table 1.
3. Process Pressure-Temperature Range
4. Process Composition and Conductivity
5. Grounding Rings (if mating piping is nonmetallic, or lined metallic piping)
6. Optional Features (if not included in Model Number)
7. User Tag Data



**DIMENSIONS—NOMINAL**

**mm**  
**in**

**801SA-WCR TO 801HA-WCR CERAMIC-LINED FLOWTUBES  
USED WITH REMOTE-MOUNTED TRANSMITTERS**

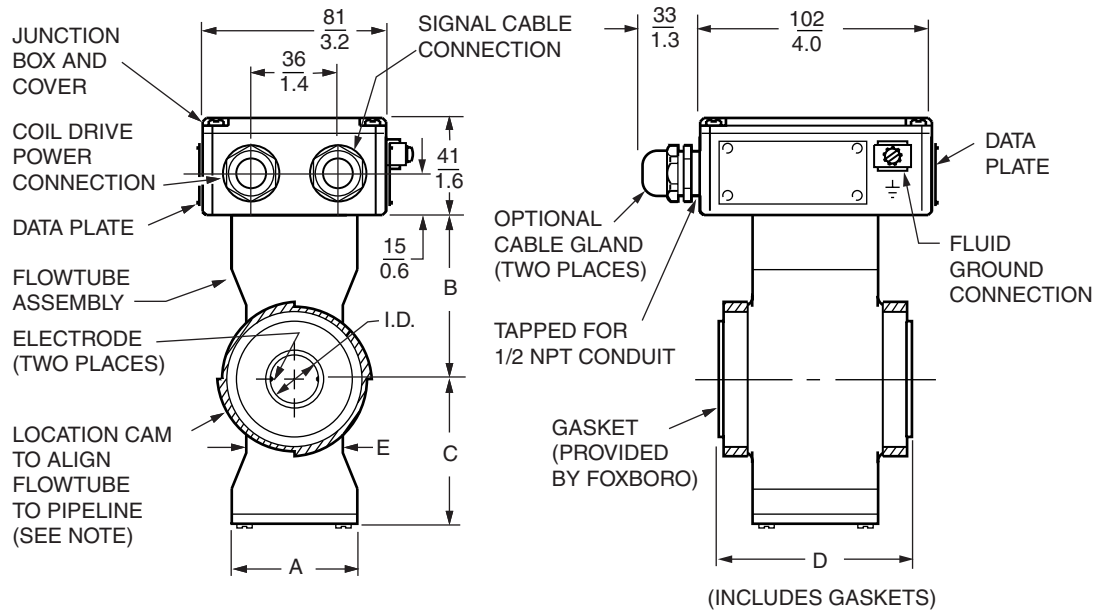

Flowtube Model	Nom. Line Size		Actual I.D.	Nominal Dimensions				
	mm	in		A	B	C	D	E
801SA-WCR (a)	1.6	1/16	1.57 0.062	53 2.1	61 2.4	58 2.3	77.7 3.06	28 1.1
801EA-WCR (a)	3	1/8	3.18 0.125	53 2.1	61 2.4	58 2.3	77.7 3.06	28 1.1
801QA-WCR (a)	6	1/4	5.33 0.210	53 2.1	61 2.4	58 2.3	77.7 3.06	28 1.1
800HA-WCR	15	1/2	12.70 0.500	53 2.1	61 2.4	58 2.3	77.7 3.06	28 1.1
8001A-WCR	25	1	23.62 0.930	53 2.1	69 2.7	66 2.6	77.7 3.06	41 1.6
801HA-WCR	40	1 1/2	37.08 1.460	53 2.1	84 3.3	76 3.0	88.9 3.50	53 2.1

(a) Designed for installation between 15 mm (1/2 in) flanges.

**NOTE**

Location CAM is provided with flowtube to simplify its alignment with the following pipeline flanges:  
Metric PN 10, PN 16, PN 20, PN 25, and PN 40; and ANSI Class 150 and 300.



**DIMENSIONS—NOMINAL (Cont.)**

**mm**  
**in**

**800HA-WPR TO 801HA-WPR PFA-LINED FLOWTUBES  
USED WITH REMOTE-MOUNTED TRANSMITTERS**

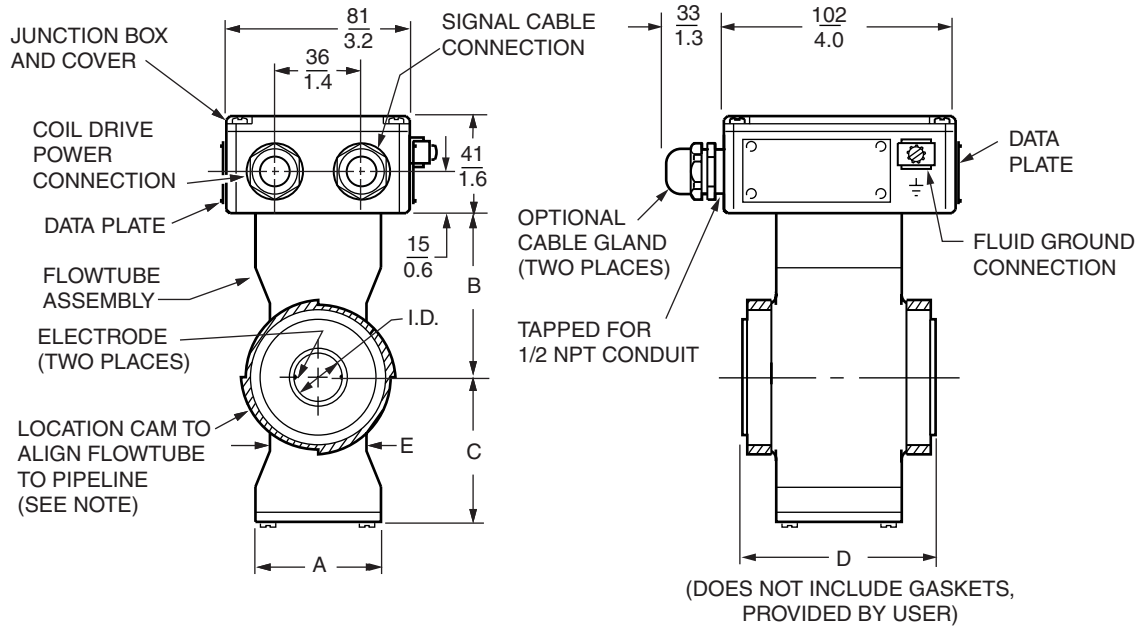

Flowtube Model	Nom. Line Size		Actual I.D.	Nominal Dimensions				
	mm	in		A	B	C	D	E
800HA-WPR	15	1/2	12.70 0.500	53 2.1	61 2.4	58 2.3	71.4 2.81	28 1.1
8001A-WPR	25	1	23.62 0.930	53 2.1	69 2.7	66 2.6	71.4 2.81	41 1.6
801HA-WPR	40	1 1/2	37.08 1.460	53 2.1	84 3.3	76 3.0	82.6 3.25	53 2.1

**NOTE**

Location CAM is provided with flowtube to simplify its alignment with the following pipeline flanges:  
Metric PN 10, PN 16, PN 20, PN 25, and PN 40; and ANSI Class 150 and 300.

**DIMENSIONS—NOMINAL (Cont.)**

**mm  
in**

**8002A-WPA TO 8006A-WPR PFA-LINED FLOWTUBES  
USED WITH REMOTE-MOUNTED TRANSMITTERS**

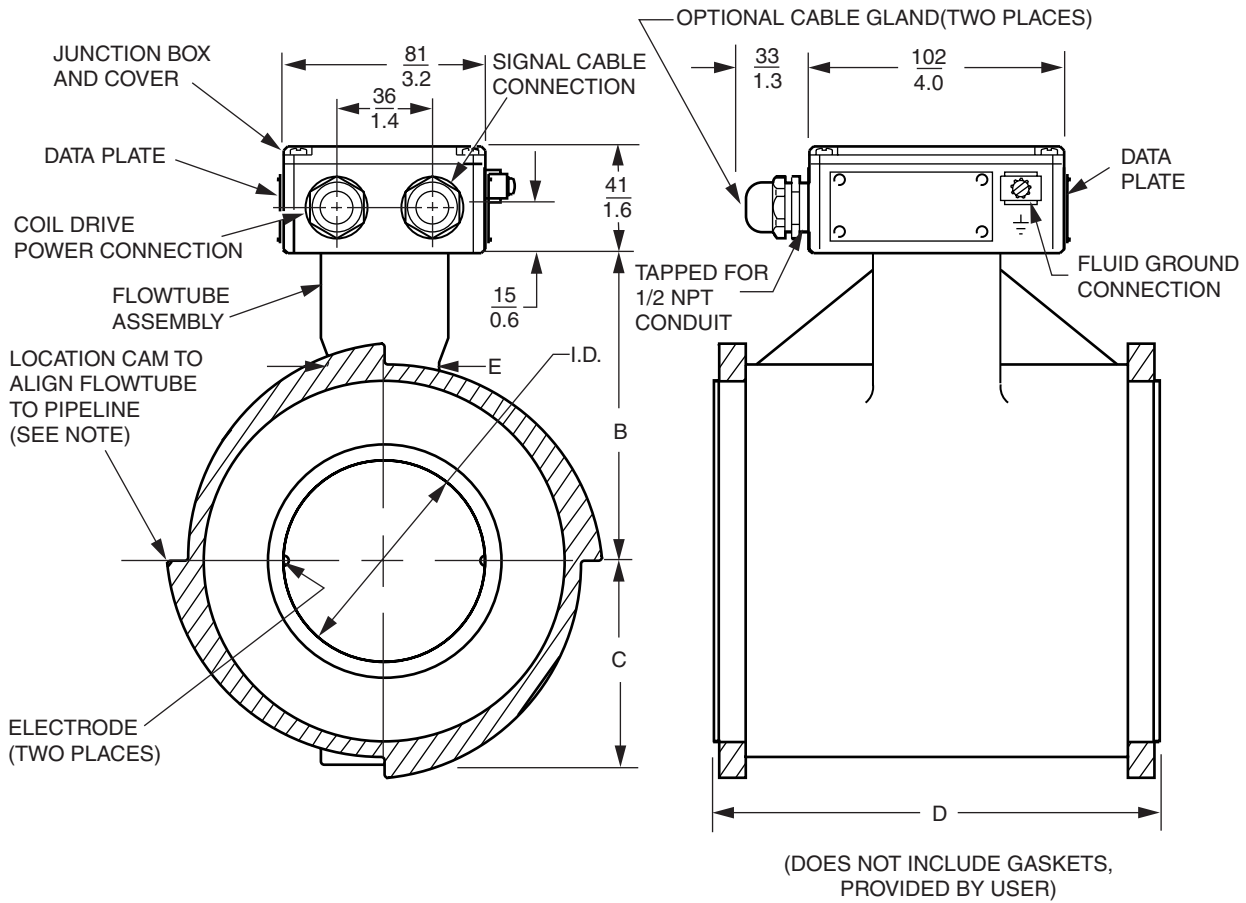

Flowtube Model	Nom. Line Size		Actual I.D.	Nominal Dimensions			
	mm	in		B	C	D	E
8002A-WPR	50	2	45.0 1.77	91 3.6	61 2.4	106.4 4.20	28 1.1
8003A-WPR	80	3	70.6 2.78	107 4.2	76 3.0	149.2 5.88	41 1.6
8004A-WPR	100	4	94.0 3.70	135 5.3	89 3.5	184.2 7.25	41 1.6
8006A-WPR	150	6	139.7 5.50	165 6.5	114 4.5	203.2 8.00	48 1.9

**NOTE**

Location CAM is provided with flowtube to simplify its alignment with the following pipeline flanges: Metric PN 10, PN 16, PN 20, PN 25, and PN 40; and ANSI Class 150 and 300.

**DIMENSIONS—NOMINAL (Cont.)**

**mm**  
**in**

**800HA-WCT/WPT TO 8006A-WCT/WPT FLOWTUBE**  
**USED WITH 8000, IMT10, AND IMT20 FLOWTUBE-MOUNTED TRANSMITTERS**

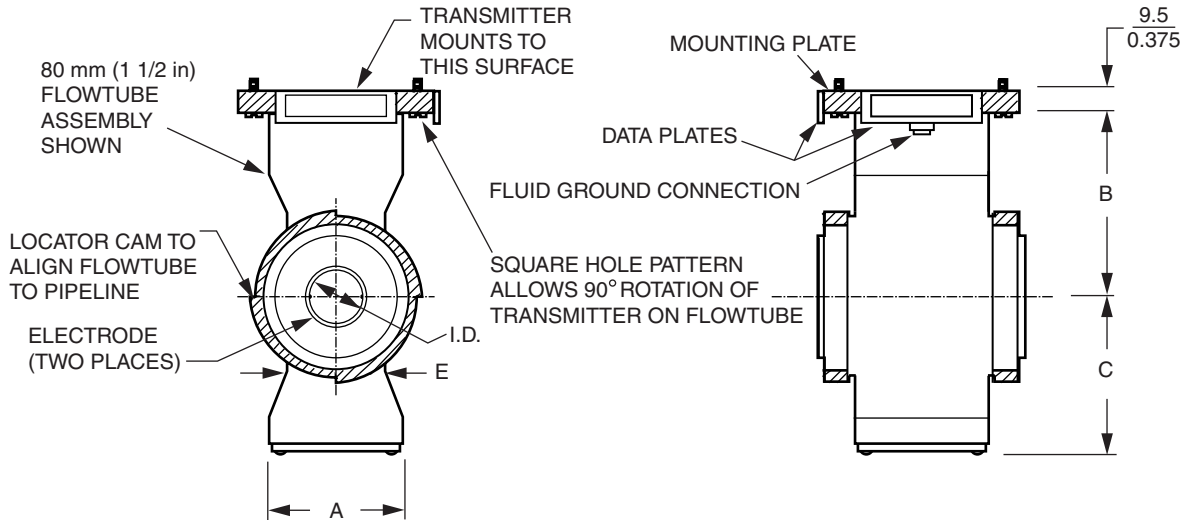

**NOTES:**

1. SEE PREVIOUS PAGES FOR FLOWTUBE DIMENSIONS.
2. SEE APPLICABLE TRANSMITTER PSS FOR TRANSMITTER DIMENSIONS.
3. FIELD WIRING IS THROUGH TRANSMITTER CONDUIT HOLES. SEE TRANSMITTER PSS.

**800HA-WCI/WPI TO 8006A-WCI/WPI FLOWTUBE**  
**USED WITH IMT25 FLOWTUBE-MOUNTED TRANSMITTERS**

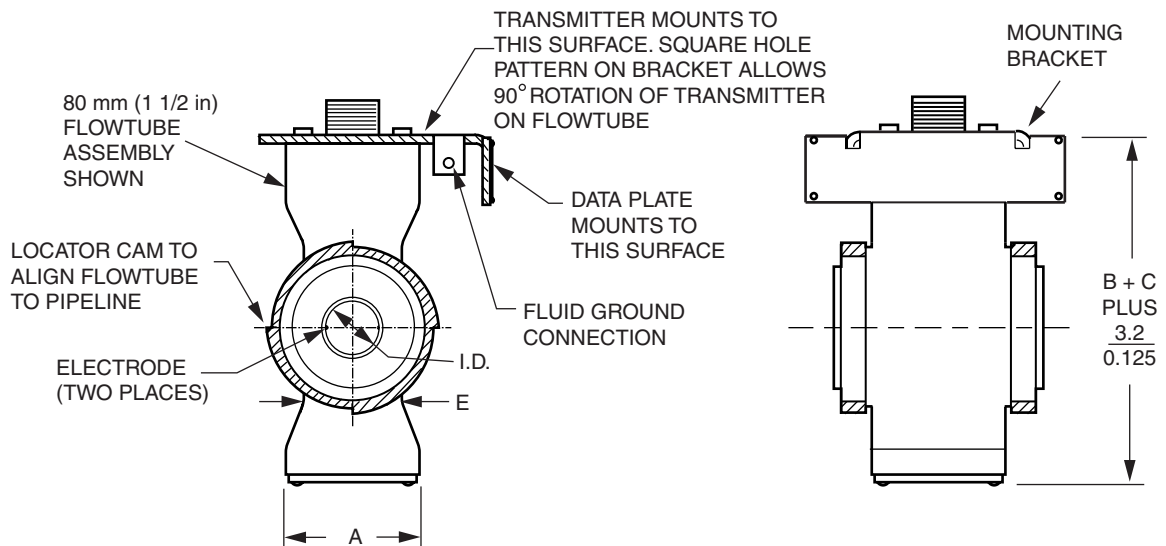

**NOTES:**

1. SEE PREVIOUS PAGES FOR FLOWTUBE DIMENSIONS.
2. SEE APPLICABLE TRANSMITTER PSS FOR TRANSMITTER DIMENSIONS.
3. FIELD WIRING IS THROUGH TRANSMITTER CONDUIT HOLES. SEE TRANSMITTER PSS.

DIMENSIONS—NOMINAL (Cont.)

mm  
in

8001A-WCI/WPI FLOWTUBE SHOWN MOUNTED TO IMT25 TRANSMITTER

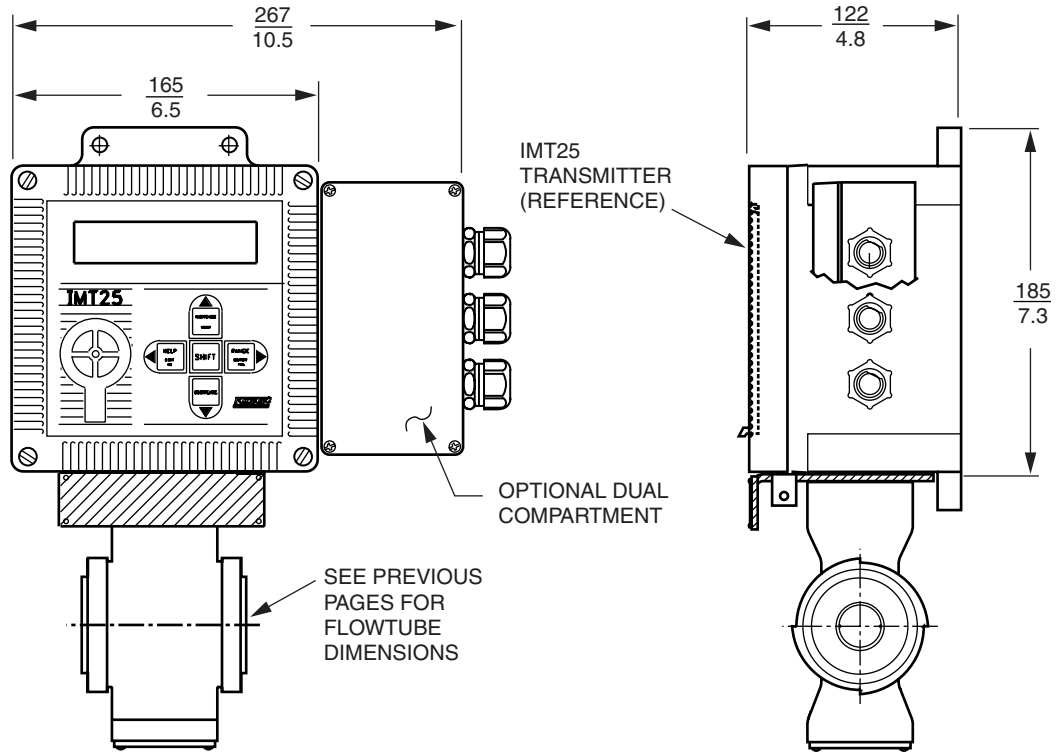

**OTHER M&I PRODUCTS**

Invensys Foxboro provides a broad range of measurement and instrument products, including solutions for pressure, flow, analytical, positioners, temperature, controlling and recording. For a listing of these offerings, visit the Invensys Foxboro web site at:

[www.foxboro.com/m&i](http://www.foxboro.com/m&i)

33 Commercial Street  
Foxboro, MA 02035-2099  
United States of America  
[www.foxboro.com](http://www.foxboro.com)  
Inside U.S.: 1-866-746-6477  
Outside U.S.: 1-508-549-2424  
or contact your local Foxboro  
representative.  
Facsimile: 1-508-549-4999

Invensys, Foxboro, Fox, and I/A Series are trademarks of Invensys plc, its subsidiaries, and affiliates.  
All other brand names may be trademarks of their respective owners.

Copyright 1995-2003 Invensys Systems, Inc.  
All rights reserved

MB 010

Printed in U.S.A.

0903